

---

**User's  
Manual**

**Model PH8EFP  
KCl Filling type pH Sensor**

IM 12B7J1-01E

---

**vigilantplant.<sup>®</sup>**



# ◆ INTRODUCTION

This manual covers the PH8EFP KCl Filling type pH Sensor.

Other related items are described in the following manuals.

Model	Title	IM No.
PH8HG	Guide-pipe Holder	IM 12B7M2-01E
PH8HF, PH8HFF	Flow-Through Type Holder	IM 12B07N01-01E
PH8HS, PH8HSF	Submersion Type Holder	IM 12B07M01-01E
HH350G	Well Bucket Type Holder	IM 19H1B1-01E
PB350G	Float Type Holder	IM 19H1E1-01E
PB360G	Vertical Type Float Holder	IM 19H1E2-01E
PH400G	pH Converter	IM 12B7C1-02E
PH450G	pH/ORP Converter	IM 12B07C05-01E
PH202G, S	pH/ORP Transmitter	IM 12B07D02-01E
PH202SJ	TIIS Intrinsic safe pH/ORP Transmitter	IM 12B07D02-11E
FLXA21	2-Wire Liquid Analyzer	IM 12A01A02-01E
PH100	Panel Mount pH Converter	IM 12B11A01-01E
WTB10-PH□	Terminal Box	IM 19D01B01-01E
PH8TBG	Terminal Box	IM 12B07W01-01E
PH8AX	Accessories for pH Meter	IM 12B07W03-01E

# ◆ For the safe use of this equipment

## ■ Safety, Protection, and Modification of the Product

- In order to protect the system controlled by the product and the product itself and ensure safe operation, observe the safety precautions described in this user's manual. We assume no liability for safety if users fail to observe these instructions when operating the product.
- If this instrument is used in a manner not specified in this user's manual, the protection provided by this instrument may be impaired.
- Be sure to use the spare parts approved by Yokogawa Electric Corporation (hereafter simply referred to as YOKOGAWA) when replacing parts or consumables.
- Modification of the product is strictly prohibited.
- The following symbols are used in the product and user's manual to indicate that there are precautions for safety:

## ■ Notes on Handling User's Manuals

- Please hand over the user's manuals to your end users so that they can keep the user's manuals on hand for convenient reference.
- Please read the information thoroughly before using the product.
- The purpose of these user's manuals is not to warrant that the product is well suited to any particular purpose but rather to describe the functional details of the product.
- No part of the user's manuals may be transferred or reproduced without prior written consent from YOKOGAWA.
- YOKOGAWA reserves the right to make improvements in the user's manuals and product at any time, without notice or obligation.
- If you have any questions, or you find mistakes or omissions in the user's manuals, please contact our sales representative or your local distributor.

## ■ Warning and Disclaimer

The product is provided on an "as is" basis. YOKOGAWA shall have neither liability nor responsibility to any person or entity with respect to any direct or indirect loss or damage arising from using the product or any defect of the product that YOKOGAWA can not predict in advance.

## ■ Symbol Marks

Throughout this user's manual, you will find several different types of symbols are used to identify different sections of text. This section describes these icons.



### **WARNING**

---

---

Indicates a potentially hazardous situation which, if not avoided, could result in death or serious injury.

---

---



### **CAUTION**

---

Indicates a potentially hazardous situation which, if not avoided, may result in minor or moderate injury. It may also be used to alert against unsafe practices.

---



### **IMPORTANT**

---

Indicates that operating the hardware or software in this manner may damage it or lead to system failure.

---



### **NOTE**

---

Draws attention to information essential for understanding the operation and features.

---



### Tip

---

This symbol gives information that complements the current topic.

---



### SEE ALSO

---

This symbol identifies a source to be referred to.

---

---

## ◆ After-sales Warranty

- Do not modify the product.
  
- During the warranty period, for repair under warranty consult the local sales representative or service office. Yokogawa will replace or repair any damaged parts. Before consulting for repair under warranty, provide us with the model name and serial number and a description of the problem. Any diagrams or data explaining the problem would also be appreciated.
  - If we replace the product with a new one, we won't provide you with a repair report.
  - Yokogawa warrants the product for the period stated in the pre-purchase quotation. Yokogawa shall conduct defined warranty service based on its standard. When the customer site is located outside of the service area, a fee for dispatching the maintenance engineer will be charged to the customer.
  
- In the following cases, customer will be charged repair fee regardless of warranty period.
  - Failure of components which are out of scope of warranty stated in instruction manual.
  - Failure caused by usage of software, hardware or auxiliary equipment, which Yokogawa Electric did not supply.
  - Failure due to improper or insufficient maintenance by user.
  - Failure due to modification, misuse or outside-of-specifications operation which Yokogawa does not authorize.
  - Failure due to power supply (voltage, frequency) being outside specifications or abnormal.
  - Failure caused by any usage out of scope of recommended usage.
  - Any damage from fire, earthquake, storms and floods, lightning, disturbances, riots, warfare, radiation and other natural changes.
  
- Yokogawa does not warrant conformance with the specific application at the user site. Yokogawa will not bear direct/indirect responsibility for damage due to a specific application.
  
- Yokogawa Electric will not bear responsibility when the user configures the product into systems or resells the product.
  
- Maintenance service and supplying repair parts will be covered for five years after the production ends. For repair for this product, please contact the nearest sales office described in this instruction manual.

# Model PH8EFP

## KCl Filling type pH Sensor

IM 12B7J1-01E 7th Edition

## CONTENTS

◆	<b>INTRODUCTION</b> .....	<b>i</b>
◆	<b>For the safe use of this equipment</b> .....	<b>ii</b>
◆	<b>After-sales Warranty</b> .....	<b>iv</b>
<b>1.</b>	<b>Specification</b> .....	<b>1-1</b>
1.1	<b>Standard Specifications</b> .....	<b>1-1</b>
1.2	<b>Model and Suffix codes</b> .....	<b>1-3</b>
1.3	<b>External Dimensions</b> .....	<b>1-5</b>
<b>2.</b>	<b>Installation</b> .....	<b>2-1</b>
2.1	<b>Preparation for Installation</b> .....	<b>2-1</b>
2.1.1	Unpacking and Inspection .....	2-1
2.1.2	Mounting Glass Electrode .....	2-2
2.1.3	Mounting Liquid Junction .....	2-2
2.1.4	Installing Holder .....	2-2
2.1.5	Installing Associated Instruments .....	2-2
2.2	<b>Requirements for mounting the pH sensor</b> .....	<b>2-3</b>
2.2.1	In case of installing the PH8HG Guide-pipe Holder .....	2-3
2.2.2	Installing Sensor in PH8HS Submersion Holder .....	2-5
2.2.3	Installing Sensor in Flow-through Holder .....	2-8
2.3	<b>pH Sensor Cable Wiring Procedure</b> .....	<b>2-11</b>
2.3.1	Processing of Cable Inlet Hole .....	2-11
2.3.2	Connecting Sensor Cable .....	2-11
2.3.3	Connecting Sensor Cable to Two-wire pH Transmitter .....	2-12
2.3.4	Connecting Sensor Cable to Four-wire pH Converter .....	2-13
<b>3.</b>	<b>Maintenance on operation</b> .....	<b>3-1</b>
3.1	<b>Operation and Periodic Maintenance</b> .....	<b>3-1</b>
3.1.1	Calibrating pH Sensor Using Buffer Solutions .....	3-1
3.1.2	Pressurizing Reserve Tank .....	3-1
3.1.3	Replenishment of KCl Solution .....	3-1
3.1.4	Cleaning Glass Electrode and Liquid Junction .....	3-2
3.2	<b>Replacing Consumable Parts</b> .....	<b>3-3</b>
3.2.1	Replacing Glass Electrode .....	3-3
3.2.2	Replacing Liquid Junction .....	3-3

3.2.3 Replacing O-rings for Glass Electrode ..... 3-3

**Customer Maintenance Parts List..... CMPL 12B05J01-02E**

**Revision Information .....i**



# 1. Specification

The Model PH8EFP KCl filling type pH Sensor permits stable pH measurement even for solutions having comparatively severe properties. This sensor can be mounted on either an PH8HF flow-through holder or an PH8HS submersion holder, or its can be used alone suspended in the solution (maximum depth 3 meters).

## 1.1 Standard Specifications

Measurement: Hydrogen ion concentration (pH) of a solution

Measurement principle: Glass electrode method

Measuring range: 0 to 14 pH (see Table 1)

Installation: Mounting in PH8HS submersion holder  
 Mounting in PH8HG guide-pipe holder  
 Mounting in PH8HF flow-through holder

Note: If any of the following solutions are measured, install the sensor either in a flow-through or submersion holder.

- When the solution temperature exceeds 80°C.
- When the pH of the solution is 2 or less or 12 or greater.
- When a strong acid solution is to be measured (e.g., aqua regia, chromic acid, hypochlorous acid or perchloric acid, etc.).
- When the solution contains corrosive gases (e.g., ammonia, chlorine, hydrogen sulfide, etc).
- When the solution contains a small percentage of organic solvent or oil.

Solution temperature: -5 to 105°C  
 when mounted in PH8HG guid-pipe holder: -5 to 80°C  
 when mounted in PH8HS, PH8HF holder, see Table 1.

**Table 1. Process Temperature Range**

Holder Type	Holder Material	Solution pH Range	Cleaner	Solution Temperature (°C)
Guide-pipe (PH8HG)	PVC	2 to 12	None	-5 to 50
	PP			-5 to 80
Submersion (PH8HS)	PP	0 to 14	None	-5 to 100
			Provided	-5 to 80
	S3 *2		None	-5 to 100
			Provided	-5 to 80
Flow-through (PH8HF) *1	PP		None	-5 to 80
			Provided	-5 to 80
	S3 *2		None	-5 to 105
			Provided	-5 to 80

PVC: Hard PVC  
 PP: Polypropylene  
 S3: SUS 316

Notes:

- (\*1): For flow-through types, refer also to the solution temperature and pressure graph (in notes following Model and Suffix code table for flow-through type holders).  
 (\*2): Solutions with normal pH ranges of 3 to 14 are recommended for stainless steel (SUS316).

Temperature compensation sensor : Pt1000  
 Solution pressure : Under atmospheric pressure to 10 kPa (General purpose or big volume tank 500 ml) (See Table 2 when using holder)  
 Atmospheric pressure to 500 kPa (Medium pressure tank)  
 (See Table 2 when using holder)

**Table 2. Process Pressure Range**

Holder	Process Pressure Range
Submersion	Atmospheric pressure (Submersion depth: Max. 3 m)
Guide-pipe Suspension Float	Atmospheric pressure (Submersion depth: Max.3 m)
Flow-through	Atmospheric pressure to 10 kPa Atmospheric pressure to 500 kPa when medium pressure reserve tank used.

(Note 1) For flow-through types, refer also to the solution temperature and pressure diagram of Holder IM.

Operating solution depth : 3 m water pressure (max.) under atmospheric pressure

Solution flow velocity : 2 m/s max.

Solution flow rate : 3 to 11 l/min  
 (when the sensor is installed in a flow-through type holder).

Solution conductivity : 50  $\mu$ S/cm or higher

Wetted part materials:

Body; Ryton (PPS resin), glass, titanium or Hastelloy C, ceramics, teflon, fluorocarbon rubber or Daielperfrow rubber

Cable; Chlorinated polyethylene rubber (Cable sheath)

KCl solution supply tube: Heat-resistant soft PVC (General purpose or big volume tank 500 ml), Polyethylene (Medium pressure).

Weight: Sensor; Approx. 0.4 kg (Body), KCl Tank; Approx. 0.3 kg (General purpose),  
 Approx. 1 kg (Medium pressure),  
 Approx. 0.8 kg (Big volume)

KCl solution consumption: when pressurized with 10 kPa  
 Maximum 3 ml/day (general junction)  
 Maximum 7 ml/day (teflon junction)

Output Response: Response time (for 90% response): 10 seconds maximum (when the sensor, stabilized at 20°C, measures a solution at 20°C).

**CAUTION**

Select the material of wetted parts with careful consideration of process characteristics. Inappropriate selection may cause leakage of process fluids, which greatly affects facilities. Considerable care must be taken particularly in the case of strongly corrosive process fluid such as hydrochloric acid, sulfuric acid, hydrogen sulfide, and sodium hypochlorite. If you have any questions about the wetted part construction of the product, be sure to contact Yokogawa.

## 1.2 Model and Suffix codes

### ● pH Sensor

Model	Suffix Code	Option Code	Description
PH8EFP	.....	.....	KCl Filling Type pH Sensor
Cable Length and KCl Tube Length	-03 -05 -07 -10 -15 -20	..... ..... ..... ..... ..... .....	3m 5m 7m 10m 15m 20m
Solution Ground Tip	-TN -HC	..... .....	Titanium Hastelloy C
KCl Reserve Tank (*1)	-TT1 -TT2 -TT3 -TN1 -TN2	..... ..... ..... ..... .....	For general purpose (250ml solution inlet) For medium pressure, Big volume tank (With 500ml tank) For maintenance (for TT1, TT3) For maintenance (for TT2)
—	-N	.....	Always -N
pH Measuring System	-T -E -F -B -G	..... ..... ..... ..... .....	For PH200/PH400 (*3) For PH202/FLXA21 (*4) For FLXA21 (*10) For PH100 (*5) For PH450G,PH202/TB (*9)
Style	*A	.....	Style A
Option	O-ring Special glass electrode Special junction	/PF /HA /TF	Daielperfrow (*6) Glass electrode for high alkali (*7) Teflon junction (*8)

- \*1: 2-inch pipe mounting bracket is supplied with TT1, TT2 and TT3.  
Only a supply tube, but no KCl solution, is supplied with TN1 and TN2.  
Since a KCl solution is not supplied with TT2, arrange it from among accessories or auxiliary parts.
- \*2: Prepare an air pressure regulator as shown in the diagram below when the medium-pressure reserve tank is used.  
To pH sensor, Regulator, (to be prepared separately)

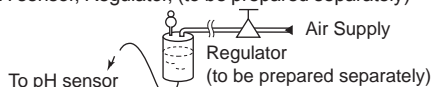

- \*3: Mark band is shown by mark and fork terminals are used.  
\*4: Mark band is shown by numeral and pin terminals are used.  
\*5: The tag which indicated the color, the sign, and the number is attached to the cable of a sensor.  
\*6: Choose Daielperfrow when this is used in organic solvent, high alkali or high temperature solution.  
\*7: Choose when using in high alkali solution.  
\*8: Choose when using in the heavily contaminated application.  
\*9: Mark band is shown by numeral and M3 ring terminals are used.  
When terminal box is used, select WTB10-PH3.  
\*10: Mark band is shown by numeral and M4 ring terminals are used.  
When terminal box is used, select WTB10-PH5.

### ● Accessories

Model	Suffix Code	Option Code	Description
PH8AX	.....	.....	Accessories for pH meter (*1)
Calibration Reagents	-L -P	..... .....	Two bottles, each containing 250ml solution (pH7 and pH4) 24 bags, each bag containing powder for 500ml solution (pH7 X 12 bags and pH4 X 12 bags) and two 500ml polyethylene bottles.
Style	*A	.....	Style A
Option (*2)		/STD /KCLL /KCLP /TMP	Sensor stand (with mounting bracket for 2-inch pipe) KCl solution (one 250 ml polyethylene bottle) KCl powder (three bags, 250 ml solution each) Thermometer (0 to 100 °C)

- \*1: Including the following:  
Two 200 ml polyethylene cups  
One cleaning bottle
- \*2: Either /KCLL or /KCLP is required for PH8EFP-□□-□□-TT2.

- Consumables

Part Name		Part Number	Remarks
Glass electrode	General purpose	K9142TN	One
		K9319NA	One for /PF option
	Certified version	K9142TP	One for /K option
		K9319NB	One for /K/PF option
	High alkali	K9142TU	One for /HA option
		K9319NC	One for /HA, /PF option
Junction	General purpose	K9142TH	One
		K9319QA	One for /PF option
	Teflon	K9142HW	One for /TF option
		K9319QB	One for /TF/PF option
KCl solution (3.3mol/l)		K9084LP	Six 250 ml polyethylene bottles
Buffer solution for calibration (pH 4)		K9084LL	Six 250 ml polyethylene bottles
Buffer solution for calibration (pH 7)		K9084LM	Six 250 ml polyethylene bottles
Buffer solution for calibration (pH 9)		K9084LN	Six 250 ml polyethylene bottles
Powder for buffer solution (pH 4)		K9020XA	12 bags, each for preparation of 500 ml
Powder for buffer solution (pH 7)		K9020XB	12 bags, each for preparation of 500 ml
Powder for buffer solution (pH 9)		K9020XC	12 bags, each for preparation of 500 ml

(Note) The pH value of the calibrating buffer solution may vary depending on storage conditions.  
Prepare a new solution from powder for accurate instrument calibration

# 1.3 External Dimensions

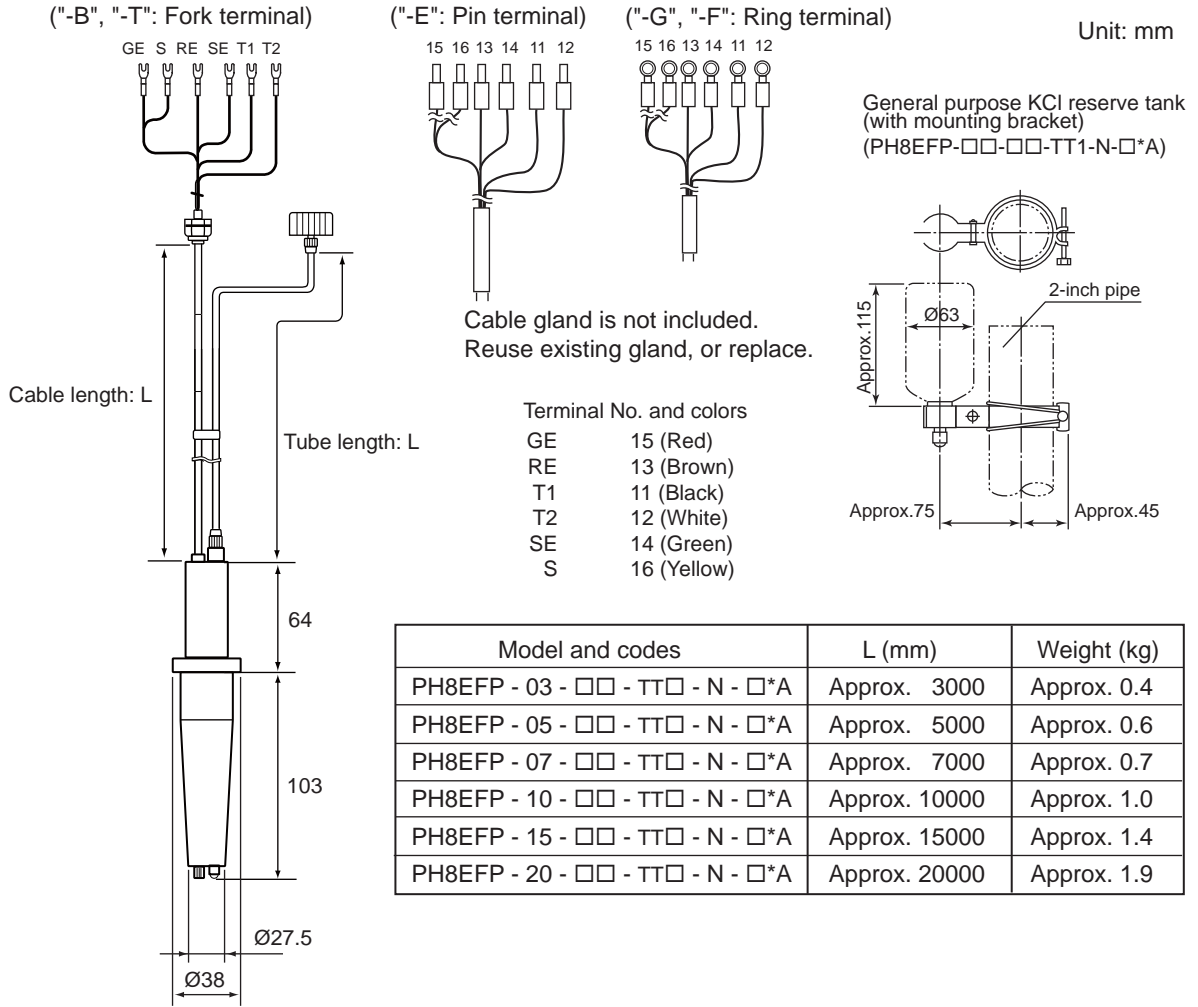

Medium pressure KCl reserve tank (with mounting bracket) (PH8EFP-□□-□□-TT2-N-□\*A)

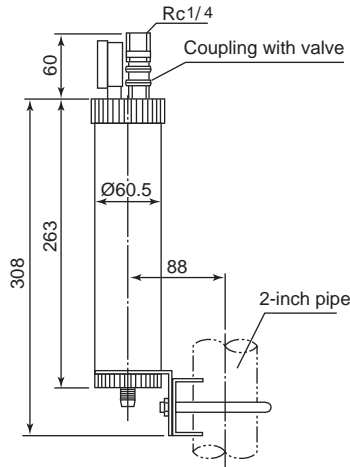

Big volume KCl reserve tank (with mounting bracket) (PH8EFP-□□-□□-TT3-N-□\*A)

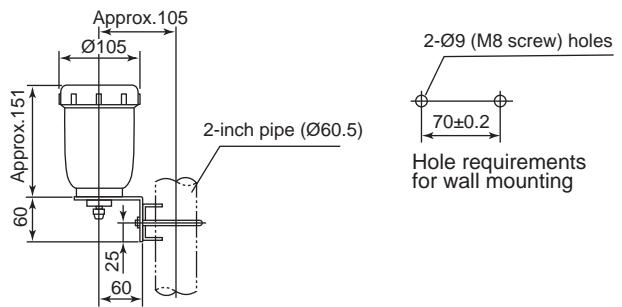

F1.1.ai

Figure 1.1 PH8EFP Filling type pH Sensor



# 2. Installation

## 2.1 Preparation for Installation

### 2.1.1 Unpacking and Inspection

The Model PH8EFP pH sensor is well packed so as to prevent damage during shipment. After removing the sensor from its shipping container, visually check the sensor for damage.



#### NOTE

1. When delivered, the "glass electrode" and the "liquid junction" are packed separate from the sensor body.
2. So that caps of the "glass electrode" and the "liquid junction" do not dry out, do not take unpack these at this time.

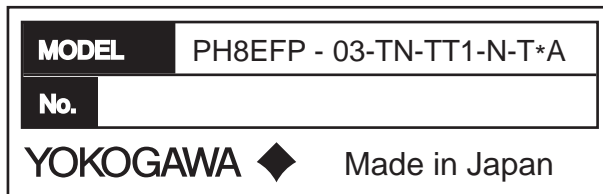

F2.1.ai

Figure 2.1 An Example of Model Number Entering to Nameplate

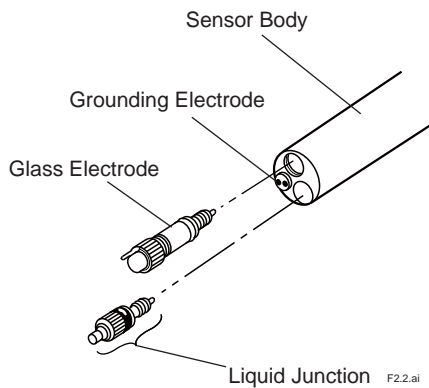

F2.2.ai

Figure 2.2 Names of PH8EFP pH Sensor Components

### 2.1.2 Mounting Glass Electrode

Mount the glass electrode on the sensor body as per the following procedure:

- (1) Peel off the seal from the electrode mounting hole on the sensor body.
- (2) Remove the cap for the glass membrane. Wipe off any solution remaining on the O-ring with a tissue or other material.
- (3) Remove the cap for the gold-plated pin.
- (4) Confirm that there is no damage on the O-ring that might affect its sealing performance.
- (5) Mount the glass electrode on the sensor body. Insert the electrode in the mounting hole and screw it clockwise until the O-ring fits tightly in the hole.



#### NOTE

- As shown in Figure (a), the cap for the glass membrane contains the solution to keep wet (pH4 buffer solution). Do not splash the solution when removing the cap. Remove the cap carefully because the rod beside the glass membrane is very fragile.
- Before mounting the glass electrode on the sensor body, make sure that the O-ring and the gold-plated pin are not wet. Wipe off any remaining solution.
- Make sure that there are no droplets in the mounting hole. Wipe off any droplets, or they may cause insulation failure.
- Use the electrode within one year after purchase. The solution to keep wet gradually evaporates over time. A glass electrode whose glass membrane has dried out does not provide stable readings until it gets used to the solution. As shown in Figure (b), place in advance the glass electrode either in the pH4 or pH7 buffer solution for more than a day before using.

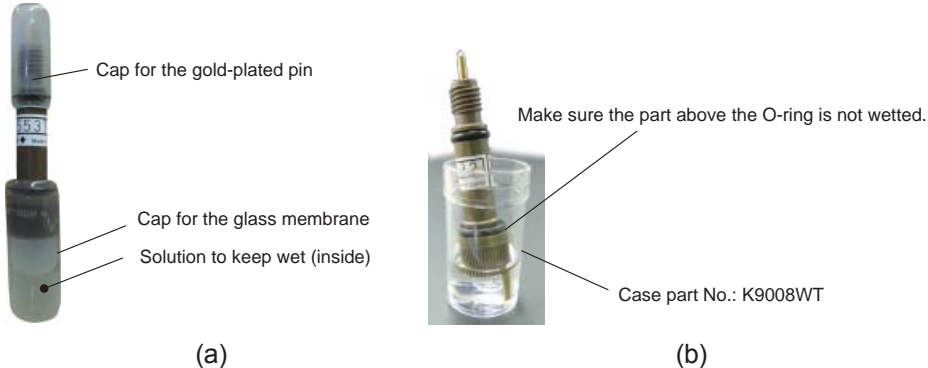

### 2.1.3 Mounting Liquid Junction

The liquid junction is mounted in the sensor body when the KCl solution is poured into the sensor body. Refer to Section 2.2.

### 2.1.4 Installing Holder

Usually, the pH sensor is suspended in a guide pipe or installed in a flow-through or submersion holder. First install the holder.

### 2.1.5 Installing Associated Instruments

Make sure that the associated instrument (a pH transmitter/converter or a junction terminal box) to which the pH sensor cable is connected has already been installed.



## 2.2 Requirements for mounting the pH sensor

### 2.2.1 In case of installing the PH8HG Guide-pipe Holder

To install the sensor in the guide pipe, proceed as follows:

- (1) Connect the sensor cable to the associated instrument correctly by referring to Section 2.3 provided later.
- (2) Mount the liquid junction in the sensor body. Peel off the seal attached to the liquid junction mounting hole in the sensor body. Screw the liquid junction gently two or three turns into the hole.
- (3) If specified, a reserve tank containing 250 ml KCl solution and mounting hardware to hold this tank are supplied with the PH8EFP pH sensor. Attach the holding hardware to the pipe (nominal diameter 50 mm). Connect the reserve tank to the KCl solution supply tube of the sensor. Remove the cap from the tank and screw the tube connector securely into the tank.
- (4) Supply KCl solution to the sensor (see Figure 2.3). First, mount the reserve tank on the mounting hardware with the tube connection part directed downwards. Using the pin supplied with the tank, make several holes at its top (see Figure 2.3). Stand the sensor upside down at a lower position than the reserve tank as shown in Figure 2.3 so that KCl solution flows from the tank into the sensor. When the KCl solution fills the sensor and overflows from the liquid junction mounting hole, securely screw the liquid junction into the mounting hole.

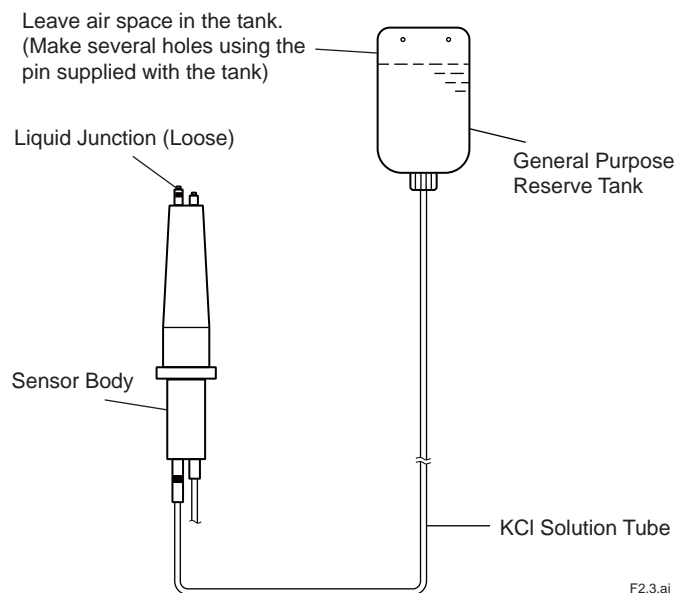

**Figure 2.3 Supplying KCl Solution to Sensor Body**



#### SEE ALSO

For the Big-volume reserve tank, refer to page 2-9 to 2-10.

- (5) Attach the "stopper" supplied with the guide pipe to the sensor cable.

Fix the sensor cable so that the sensor tip projects 20 to 30 mm out from the pipe end when the pH sensor is suspended in the guide pipe as shown in Figure 2.4.



## NOTE

If the sensor tip does not project out from the pipe end, the measured value may not respond promptly to the pH variations of the measured solution. This may cause problems for pH measurement and control. On the other hand, if the sensor tip projects too far from the pipe end, the force on the sensor may damage the sensor cable from scraping it against the pipe.

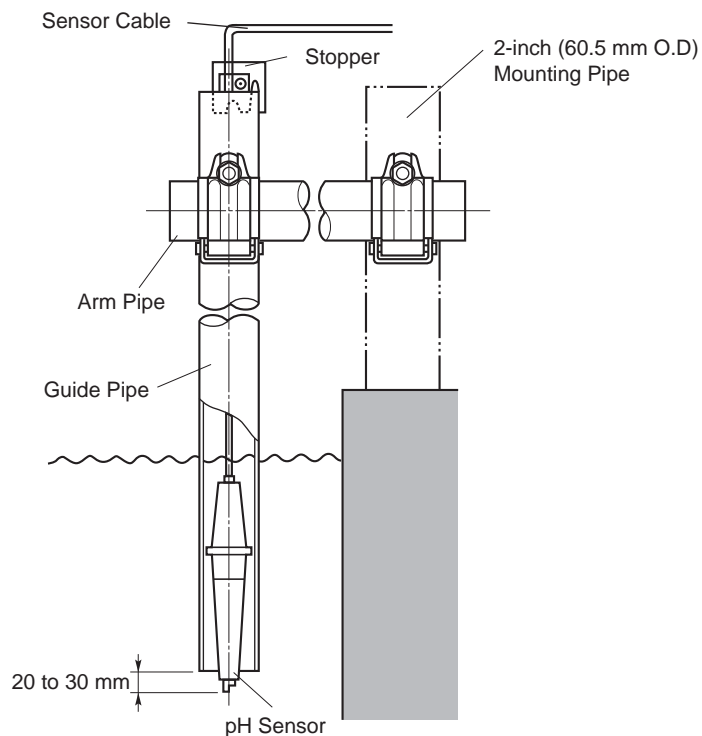
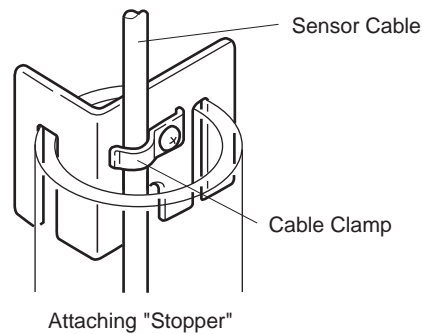

**Figure 2.4 Mounting Sensor in Guide Pipe**

### 2.2.2 Installing Sensor in PH8HS Submersion Holder

To install the sensor in the submersion holder, proceed as follows:

- (1) Pass the sensor cable through the sensor holder. If the submersion holder remains installed, remove the sensor holder in any case.

For a pipe-mounting submersion holder without a cleaner, loosen the sensor holder nut to remove the holder.

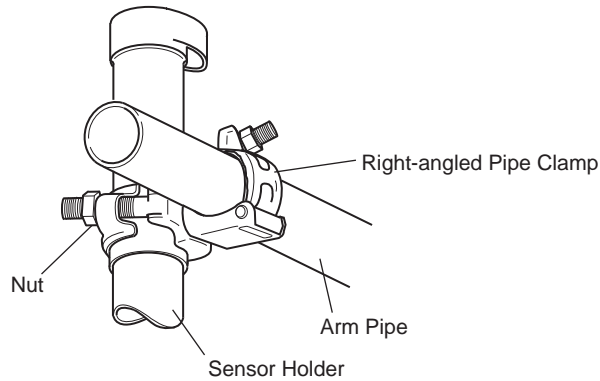

Removal of Sensor Holder (Arm Pipe used with option /MS1 or /MS2)

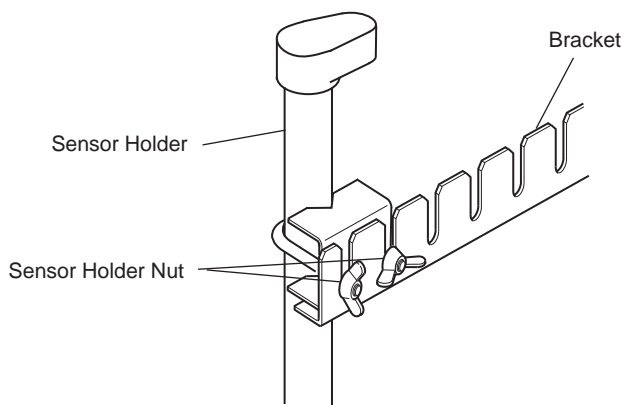

F2.5.ai

Removal of Sensor Holder (Stainless Bracket used with option /MS3 or /MS4)

**Figure 2.5 Removal of Sensor Holder (for Pipe Mounting Sensor without Cleaner)**

For a flange mounting submersion holder without a cleaner, remove the sensor holder by loosening the two bolts securing the sensor holder to the flange (see Figure 2.6).

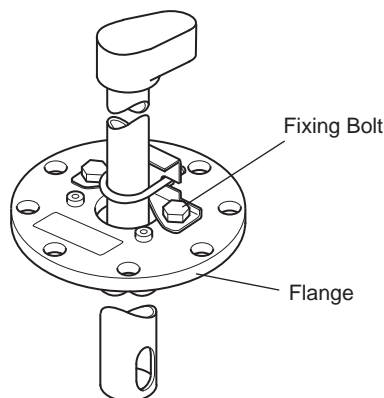

F2.6.ai

**Figure 2.6 Removal of Sensor Holder (for Flange Mounting Sensor without Cleaners)**

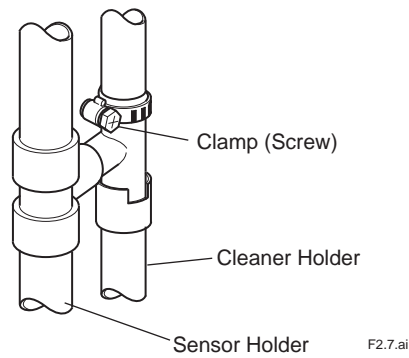

**Figure 2.7 Removal of Sensor Holder (with Cleaner)**

To install the sensor cable in the sensor holder, first remove the protector screwed onto the sensor holder end and then remove the protective foam piece (for shipping; thus, it is not necessary after the sensor is installed in the holder). Pass the sensor cable through the O-ring then attach the O-ring to the sensor flange (see Figure 2.7).

When passing the sensor cable through the holder, if the inside of the holder is dirty or wet, take special care to keep the cable dry by covering the sensor cable end with a polyethylene bag or the like.



#### SEE ALSO

---

For details to install the sensor onto a holder, refer to relevant IMs.

---

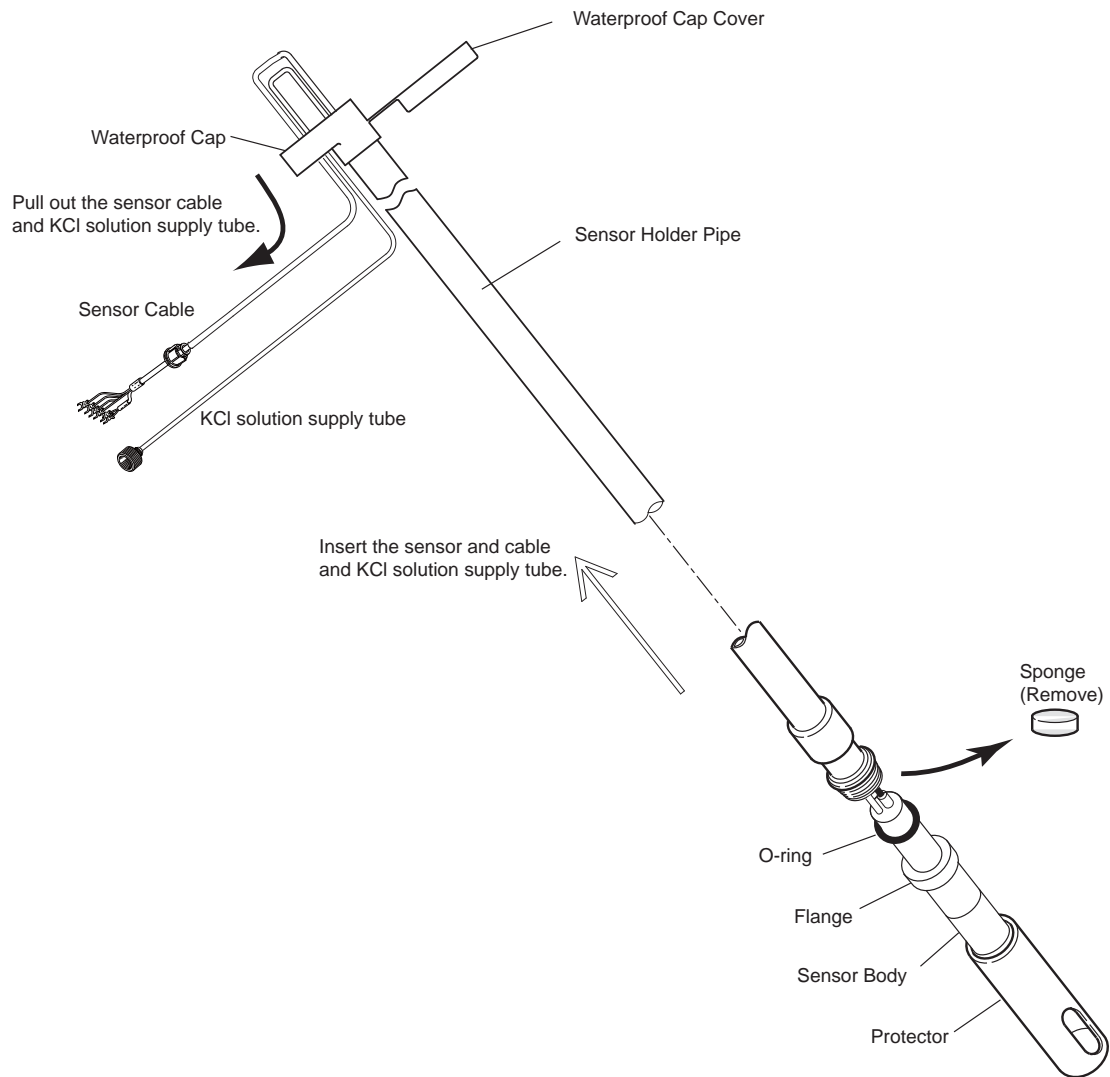

**Figure 2.8 Installing the Sensor Cable**

- (2) Connect the sensor cable to the associated instrument correctly by referring to Section 2.3.
- (3) Mount the liquid junction in the sensor body. Peel off the seal attached to the liquid junction mounting hole on the sensor body. Screw the liquid junction gently two or three turns into the hole.
- (4) If specified, a reserve tank containing 250 ml KCl solution and mounting hardware to hold this tank are supplied with the PH8EFP pH sensor. Attach the mounting hardware to the pipe (2-inch). Connect the reserve tank to the KCl solution supply tube of the sensor. Remove the cap from the tank and screw the tube connector securely into the tank.
- (5) Supply KCl solution to the sensor. First, mount the reserve tank on the mounting hardware with the tube connection part directed downwards. Using the pin supplied with the tank make several holes in its top (see Figure 2.3). Stand the sensor upside down at a position lower than the reserve tank as shown in Figure 2.3 so that KCl solution flows from the tank into the sensor. When the KCl solution fills the sensor and overflows from the liquid junction mounting hole, securely screw the liquid junction into the mounting hole.



**SEE ALSO**

For the Big-volume reserve tank, refer to page 2-9 to 2-10.

- (6) Screw the protector to fix the sensor to the holder. In this case, remove the protective cap and secure the protector so that the flange of the sensor compresses the O-ring firmly. about the installation method.

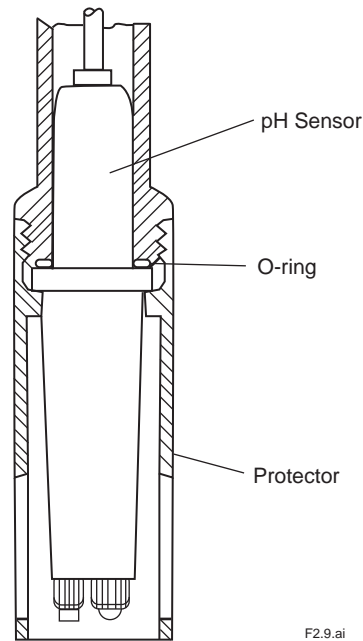

**Figure 2.9 Installing Sensor in Submersion Holder**

- (7) Close the waterproof cap, and attach the holder to the arm pipe, flange or cleaner holder completely.

### 2.2.3 Installing Sensor in Flow-through Holder

To install the sensor in a flow-through holder, proceed as follows:

- (1) Connect the sensor cable to the associated instrument. First, remove the sensor fixing nut and pass the sensor cable through the nut.

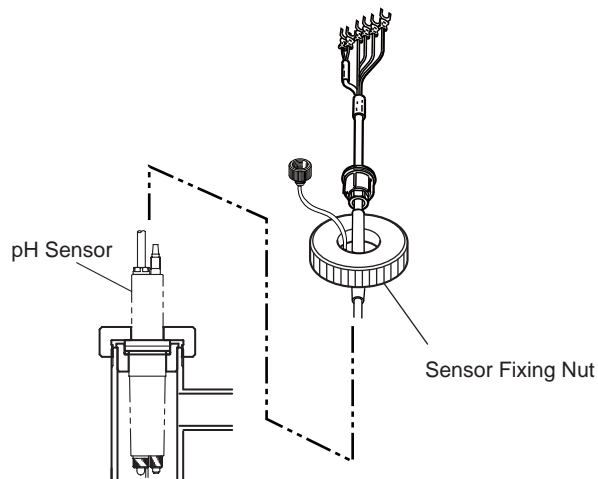

**Figure 2.10 Preparation for Sensor Cable Connection**

Properly connect the sensor cable by referring to Section 2.3.

- (2) Mount the liquid junction on the sensor body. Peel off the seal covering the liquid junction mounting hole in the sensor body. Screw the liquid junction softly into the hole by turning it for two or three turns.

- (3) If specified, a reserve tank containing 250 ml solution and mounting hardware to hold this tank, or a medium pressure reserve tank are supplied with the PH8EFP pH sensor.

Attach the mounting hardware for general purpose reserve tank to a pipe (2-inch). Connect the general purpose reserve tank to the KCl solution supply tube of the sensor. Remove the cap from the tank and screw the tube connector securely into the tank.

When using a medium pressure reserve tank, attach it to a pipe (2-inch) and perform air piping to supply pressure for reserve tank as shown in Figure 2.11. Connect the KCl supply tube of the sensor to this reserve tank.

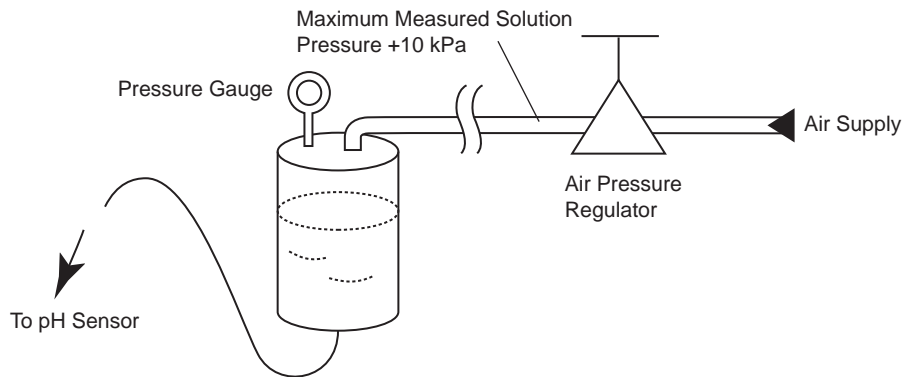

**Figure 2.11 Air Piping for Pressurizing Medium Pressure Reserve Tank**

- (4) Supply KCl solution to the sensor.

- **When a general purpose reserve tank is used.**

First, mount the reserve tank on the holding hardware with the tube connection part directed downwards. Using the pin supplied with the tank, make several holes in its top (see Figure 2.3). Stand the sensor upside down at a position lower than the reserve tank as shown in Figure 2.3 so that KCl solution flows from the tank into the sensor. When the KCl solution fills the sensor and overflows from the liquid junction mounting hole, securely screw the liquid junction into the mounting hole.

- **When a reserve tank for medium pressure is used.**

First, fill the reserve tank with KCl solution\*. Loosen the nut on the reserve tank upside and remove the cap — the pressure gauge is mounted — and pour about 250 ml of KCl solution into the tank. Stand the sensor upside down at a position lower than the reserve tank so that solution flows from the tank into the sensor. When the KCl solution fills the sensor and overflows from the liquid junction mounting hole, securely screw the liquid junction into the mounting hole. Remount the cap of the reserve tank. Tighten the nut securely.

\*: Use 3.3 mol/l KCl solution. If KCl powder (ordered separately) are supplied with the PH8AX accessories, dissolve one bag (60 g) of KCl powder in pure water to make exactly 250 ml of solution.

- **When a Big-volume reserve tank is used.**

Fill the reserve tank with a KCl solution. Loosen and remove the top cover on the reserve tank and pour a KCl solution of approximately 500 ml. When loosening or closing the cover, always do so while holding the reserve tank by hand. When further tightening the fixing nut at the bottom of the reserve tank, be careful not to tighten it too tight.

Excessive tightening may cause cracks in the reserve tank and thus leakage of KCl solutions. This will make grounding connections at two points, resulting in unstable readings or measurement errors.

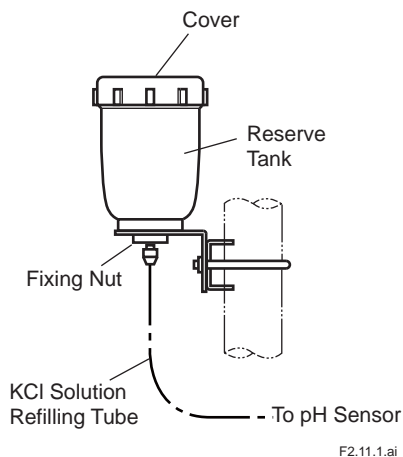

**Figure 2.11.1 Big-Volume Reserve Tank**

- (5) Connect the pH sensor to its holder. Remove the protective cap from the sensor. Also remove the protective foam piece (for shipping - this is not necessary after installing the sensor) from the holder. Be sure that the liquid junction and glass electrode are mounted properly. Insert the sensor tip into the holder and tighten the sensor fixing nut securely (see Figure 2.10).

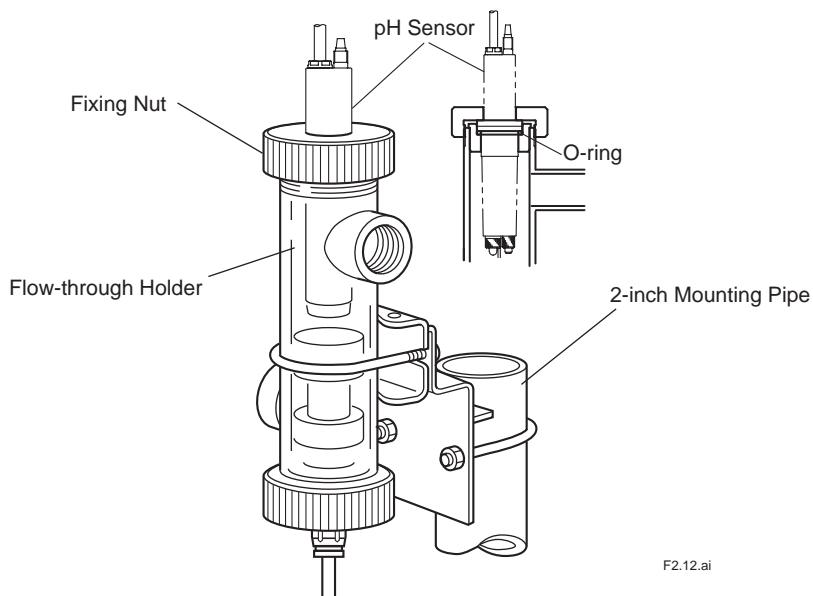

**Figure 2.12 Installing Sensor in Flow-through Holder**



**SEE ALSO**

How to install the HH350G, PB350G, and PB360G holders, refer to relevant IMs.



## 2.3 pH Sensor Cable Wiring Procedure

### 2.3.1 Processing of Cable Inlet Hole

Open the cable inlet hole in terminal box using the supplied punch tool. The location of the cable inlet hole is shown by the circle-shaped groove under the case. The end of the supplied punch tool is put in the center of this circle and it is tapped with appropriate force. You can punch out the hole along the groove.

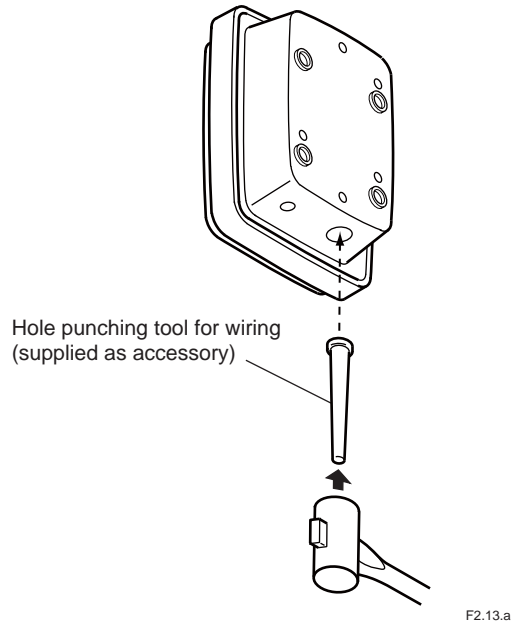

Figure 2.13 How to punch out the wiring hole

### 2.3.2 Connecting Sensor Cable

- (1) Loosen two screws which are at front of terminal box and detach the cover.
- (2) After detaching the nut from the cable gland of sensor cable, pull the cable into the terminal box from sensor cable inlet hole.
- (3) Connect the sensor cable to the terminals.

After passing the cable through the nut, check the symbol on each core wire, then connect each core wire to the corresponding terminal.

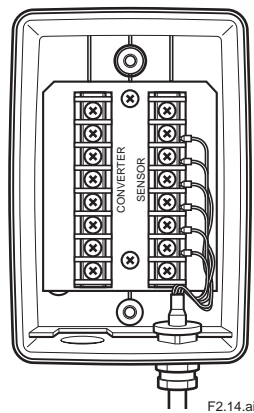
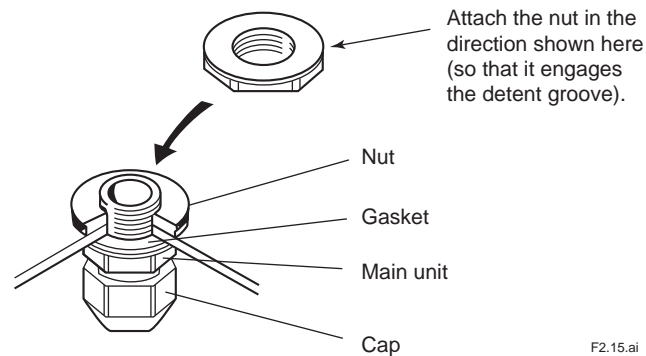

Figure 2.14 Connecting Sensor Cable (In case of the PH8TBG)

- (4) Mount the cable gland in the cable inlet hole.

Put the nut in place, and screw it onto the main body sufficiently. At this time, loosen the cap so that the cable is not twisted. After fixing the main body, tighten the cap to keep moisture out of the equipment. However if the cap is screwed up too tight, the cable will be damaged.



**Figure 2.15 Cable Gland**

- (5) After completing the cable connections, replace the box cover securely, thus preventing moisture from getting into the case.

### 2.3.3 Connecting Sensor Cable to Two-wire pH Transmitter

To connect the sensor cable to the two-wire pH transmitter, proceed as follows:

- (1) Loosen the four screws that tighten the transmitter cover. Then remove the transmitter cover.
- (2) Connect the sensor cables to the relevant terminals of the transmitter:

First, remove the nut from the cable gland. Insert the cable into the right opening for the wiring. Then pass the cable through the nut, Connect the individual cable conductors to the relevant terminals correctly by referring to the markings on the individual conductors.

For details, refer to relevant IMs.

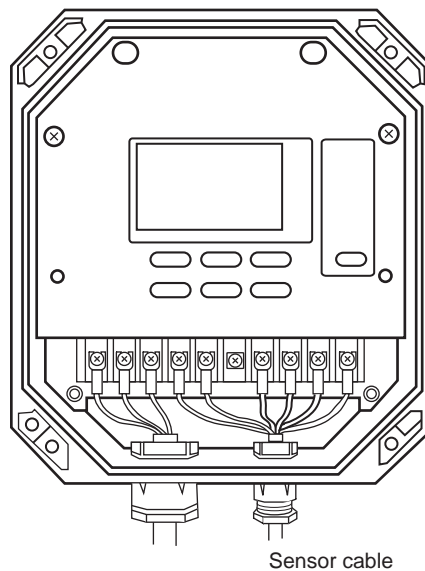

**Figure 2.16 Connecting Sensor Cable to Two-wire pH Transmitter**

- (3) Install the cable gland in the wiring hole as follows:

Pass the tip of the cable gland into the opening and completely tighten the gland with the nut inside the case.

After tightening the gland, secure the cap properly to prevent moisture from getting into the case.

Caution: Do not overly tighten the cap. Otherwise, the cable may be damaged.

- (4) After completing the cable connections, replace the transmitter cover securely, thus preventing moisture from getting into the case.

### 2.3.4 Connecting Sensor Cable to Four-wire pH Converter

To connect the sensor cable to a Four-wire pH converter, proceed as follows:

- (1) Loosen the four screws that tighten the converter cover. Then open the converter cover.
- (2) Connect the sensor cables to the relevant terminals of the converter:

First, remove the nut from the cable gland. Insert the cable into the right opening for the wiring. Then pass the cable through the nut, Connect the individual cable conductors to the relevant terminals correctly by referring to the markings on the individual conductors.

For details, refer to relevant IMs.

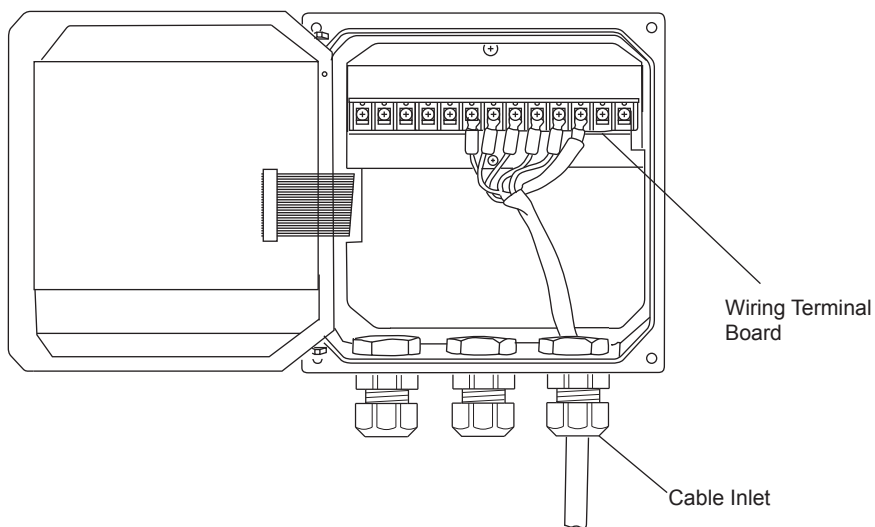

**Figure 2.17 Connecting Sensor Cable to Four-wire pH Converter**

- (3) Install the cable gland in the wiring hole as follows:

Pass the tip of the cable gland into the opening and completely tighten the gland with the nut inside the case.

After tightening the gland, secure the cap properly to prevent moisture from getting into the case.

Caution: Do not overly tighten the cap. Otherwise, the cable may be damaged.

- (4) After completing the cable connections, close the converter cover securely, thus preventing moisture from getting into the case.



## 3. Maintenance on operation

### 3.1 Operation and Periodic Maintenance

#### 3.1.1 Calibrating pH Sensor Using Buffer Solutions

Calibrate pH sensors with buffer solutions before starting normal operation because the emf of glass electrodes differs somewhat from each other.

The emf of a glass electrode gradually changes due to electrode staining or deterioration.

Therefore, buffer solution calibration must be carried out periodically within a given period of time to keep the measurement errors within the limits specified.

For more detailed information on the calibration procedures, see relevant pH transmitter/converter IMs .

#### 3.1.2 Pressurizing Reserve Tank

When the pH sensor with medium pressure reserve tank is used, apply air pressure to the reserve tank before flowing the measured solution through the holder.

Set the air pressure a little higher than the maximum pressure of the measured solution during the operation.

The flow rate of the KCl solution from the liquid junction is maximum 3 ml/day for general junction, maximum 7 ml/day for teflon junction, when the pressure difference between air and measured solution is 10 kPa , and the flow rate increases in proportion to the pressure difference. Therefore, it is important to minimize the consumption of the KCl solution by minimizing the pressure variation of the measured solution and making sure that the air pressure is not set too high.

#### 3.1.3 Replenishment of KCl Solution

When the KCl solution in the tank seems to be nearly exhausted while using a pH sensor with general type reserve tank, replace the reserve tank with new one (provided separately as spare part).

Instead of tank replacement, when a KCl solution prepared using KCl powder is used for replenishment, use 3.3 mol/l solution by dissolving 246 g of KCl powder in pure water to make exactly one liter of solution. When pouring the solution into the tank, be careful that KCl solution does not overflow from the vent holes of the tank.

When a pH sensor with a medium pressure reserve tank is used, replenish the KCl solution when the KCl solution in the tank seems to be nearly exhausted. Carry out replenishment of KCl solution as follows:

- (1) Close the valves to shut off the (low of measured solution (see Figure 3.1) - first in the inlet then the outlet valves in the flow-through type holder.

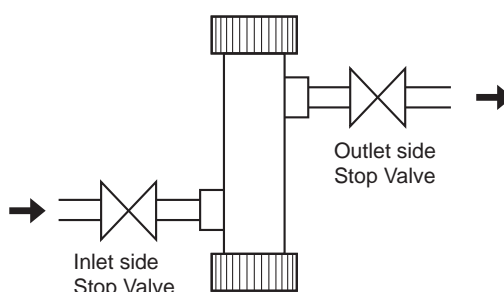

F3.1.ai

**Figure 3.1 Process Piping of Flow-through Type Holder.**

- (2) Remove the socket connector on the reserve tank and stop the air pressurizing the tank (see Figure 3.2).

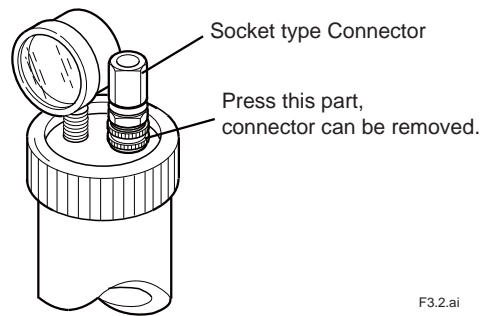

F3.2.ai

**Figure 3.2 Socket Type Connector.**

- (3) Remove the nut fixing the reserve tank cap and remove the cap.  
 (4) Refill the tank with 3.3 mol/l KCl solution (see Figure 3.3).  
 The maximum solution level 30 to 40 mm lower than the top.

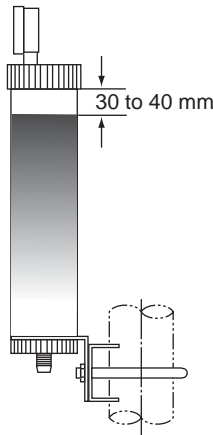

F3.3.ai

**Figure 3.3 Maximum KCl Replenishment Level**

- (5) Retighten the nut to fix the cap in position.  
 (6) Open the valve and let the measured solution flow through the holder.

### 3.1.4 Cleaning Glass Electrode and Liquid Junction

Staining of a glass electrode or liquid junction can cause measurement errors. Therefore, if the measured solutions tend to stain the electrode, the glass electrode and liquid junction must be cleaned periodically - depending on the degree of staining. If the pH sensor is installed in a holder with a cleaner, the sensor is continuously (for an ultrasonic cleaner) or intermittently (for a jet or brush cleaner) cleaned automatically.

Because of this, sensor cleaning is not usually required. However, if the sensor characteristics are affected by chemical staining, for example, when the sensor is used for pH measurement of a highly alkaline solution, carry out acid washing.

To clean the glass electrode or liquid junction, proceed as follows:

- **Stains due to suspended Solids, Sticky Materials, Microbes or the like**

Using soft tissue paper, wipe the stains off the glass electrode or liquid junction. In addition, clean off remaining stains by rinsing with water.

- **Stains due to Oily Materials**

Wash off stains by submerging in a neutral detergent solution in a beaker, etc, (for from several tens of minutes to several hours depending on the degree of staining).

- **Chemical Stains such as due to Metallic Adsorption**

Place the glass electrode or liquid junction in a diluted hydrochloric acid solution (1 to 2%) for several minutes (acid washing).

## 3.2 Replacing Consumable Parts

### 3.2.1 Replacing Glass Electrode

If buffer solution calibration becomes impossible due to deterioration of the glass electrode, replace it with a new one. After the glass electrode is replaced, always carry out a buffer solution calibration.

### 3.2.2 Replacing Liquid Junction

Even after washing the liquid junction, if normal measurement cannot be made, replace the liquid junction.

When replacing the liquid junction, fill the sensor with KCl solution to just before the solution overflows through the liquid junction mounting hole. Use a 3.3 mol/l KCl solution (a higher concentration of KCl or KCl powder) for this application.

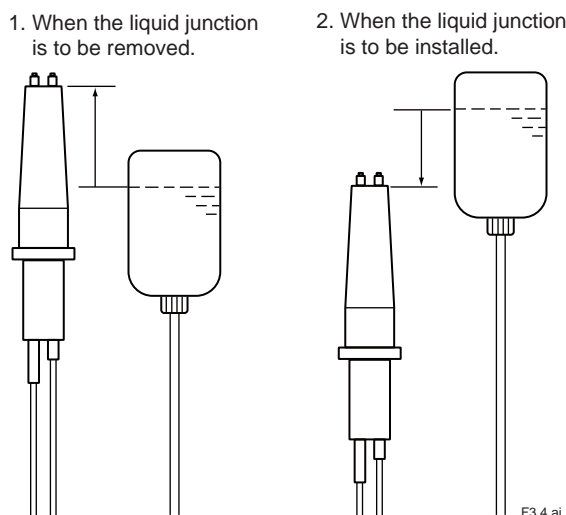

Figure 3.4 Replacing Liquid Junction

### 3.2.3 Replacing O-rings for Glass Electrode

As the inside of the glass electrode mounting hole must have high insulation resistance, fluorocarbon rubber O-rings - with superior chemical and heat resistance - are used for sealing. Except for special uses, this O-ring does not need individual replacement. If any damage - which might cause problems - is detected in the O-ring, as a rule, replace it along with the glass electrode.

Although the O-ring can be replaced individually if the O-ring deteriorates much faster than the glass electrode, it is recommended that the whole glass electrode be replaced to avoid possible deterioration of the O-ring inside the glass electrode. For individual replacement of the O-ring, use the one recommended by Yokogawa.

When installing the O-ring, wind a slip of paper or tape around the thread part on the glass electrode so as not to scratch the O-ring. Otherwise, such scratches may damage its sealing properties.

For ordering, refer to the Customer Maintenance Parts List (CMPL) at the end of the book to check the appropriate part number of the O-ring.

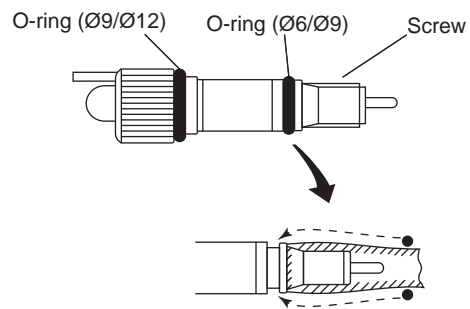

Before installing, wind a slip of paper or tape around the thread part to prevent scratches.

**Figure 3.5 Installing the O-ring**



# Customer Maintenance Parts List

## Model PH8EFP KCl Filling type pH Sensor

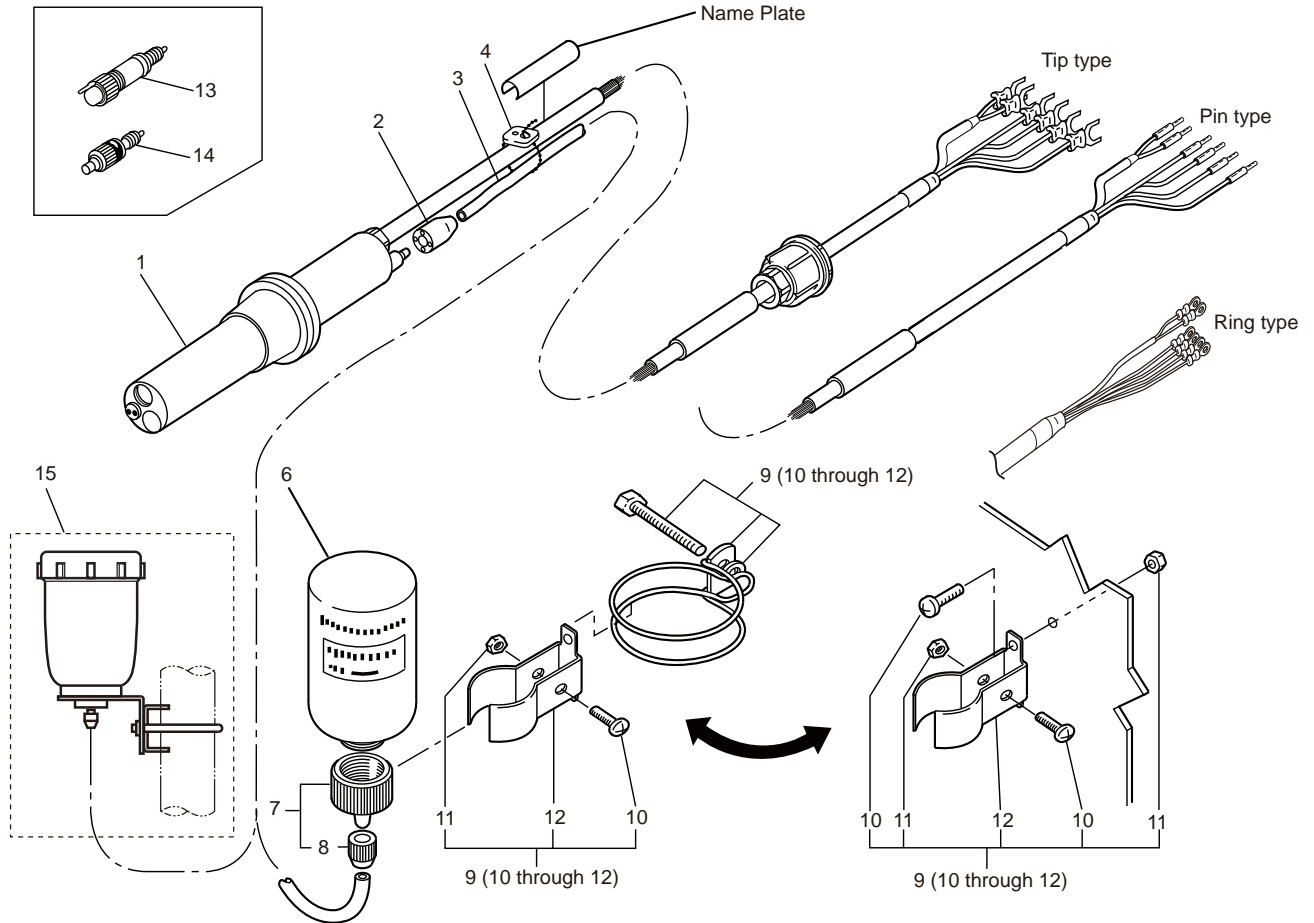

Item	Part No.	Qty	Description	Item	Part No.	Qty	Description
1	Below	1	Body Assembly see GS 12B07B02(E)	13	Below	1	Glass Electrode Assembly for general use
2	K9142EJ	1	Cap	K9142TN	1	1	for PH8EFP/PF
3	Below	1	KCl Filling Tube	K9319NA	1	1	for PH8EFP/HA and /PF
	K9142PF		Length 3 m	K9319NC	1	1	for Approved Under the Japanese Measurement Law (/K)
	K9142PG		Length 5 m	K9142TP	1	1	for PH8EFP/PF Approved Law for High Alkali of PH8EFP/HA
	K9142NH		Length 7 m				
	K9142NJ		Length 10 m	K9319NB	1	1	O-Ring
	K9142NK		Length 15 m	K9142TU	1	1	for general use, 6 mm ID. x 9 mm OD.
	K9142NL		Length 20 m				
	L9901MB		Length m step (max.100)	K9142QR	1	1	for general use, 9 mm ID. x 12 mm OD.
	Below	1	For Medium Pressure	K9142QS	1	1	for PH8EFP/PF, 6 mm ID. x 9 mm OD.
4	L9813UG	3 or 5	Clamp	K9319RB	1	1	for PH8EFP/PF, 9 mm ID. x 12 mm OD.
6	K9084KQ	1	Bottle for general use (250 ml) (Suffix Code: -TT1)	14	Below	1	Junction Assembly
7	K9084KV	1	Connector Assembly (for general use)	K9142TH	1	1	for general use
8	K9084CG	1	Nut	K9319QA	1	1	for PH8EFP/PF
9	K9142VE	1	Holder Assembly	K9142HW	1	1	for PH8EFP/TF
10	—	3	B.H. Screw, M4x18	K9319QB	1	1	for PH8EFP/TF and /PF
11	—	3	Nut	K9142UH	1	1	for PH8EFP/CJ
12	—	1	Bracket	K9142UL	1	1	for PH8EFP/CJ and /PF
				—	Below	1	O-Ring
				K9142QR	1	1	for general use, 6 mm ID. x 9 mm OD.
				K9319RB	1	1	for PH8EFP/PF, 6 mm ID. x 9 mm OD.
				15	K9142VS	1	Tank assembly for use 500 ml (Suffix Code: -TT3)

### Medium Pressure KCI Reserve Tank Assembly for Suffix Code: -TT2 ( K9142VG )

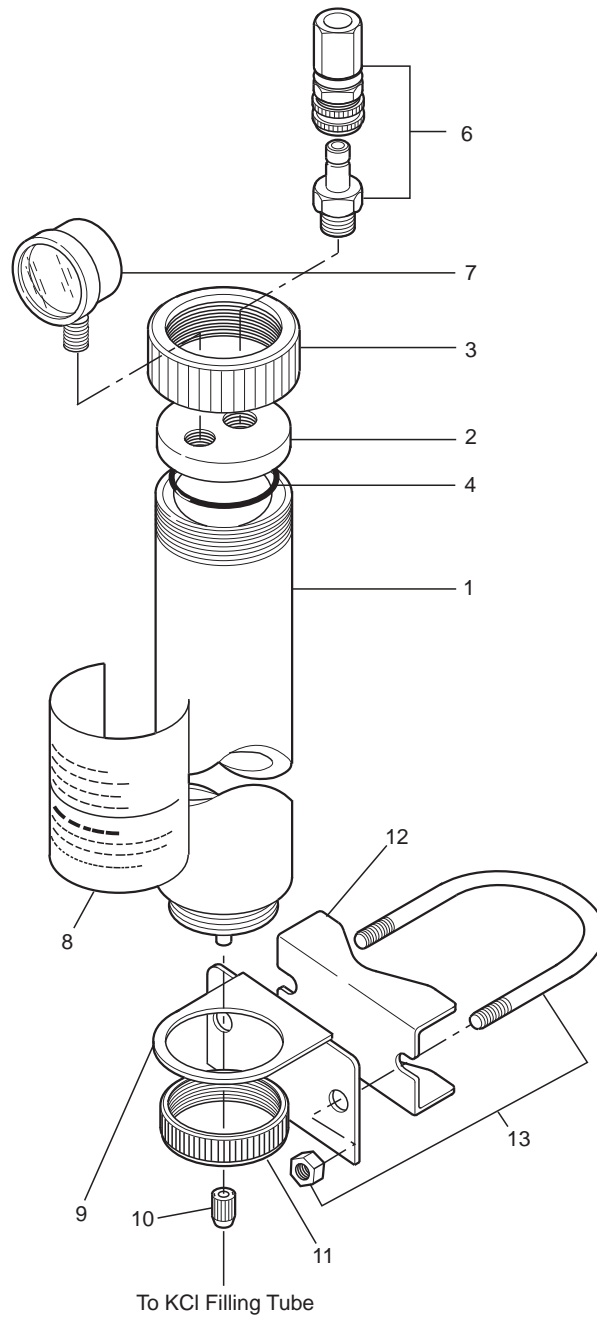

Item	Part No.	Qty	Description
1	K9142VL	1	Tank Assembly
2	K9142VJ	1	Block
3	K9142VK	1	Block
4	G9303AE	1	O-Ring
6	L9835DD	1	Joint
7	L9867BS	1	Pressure Gauge
8	K9142RU	1	Label
9	K9142VP	1	Bracket
10	K9142EJ	1	Cap
11	K9142VQ	1	Ring
12	L9826AL	1	Bracket
13	D0117XL-A	1	U-Bolt

---

# Revision Information

- Title : Model PH8EFP KCl Filling type pH Sensor
- Manual No. : IM 12B7J1-01E

## **Jun. 2013/7th Edition**

Page 2-1 to 2-2 Some revision of Sec. 2.1.1 and 2.1.2 (addition of the cap to keep the glass electrode wet); Page 3-1 to 3-4 Deletion of Sec. 3.1.1 (how to keep the glass electrode wet moved to Sec. 2.1.2) and following section no. and page layout changed; CMPL 12B05J01-02E revised to 10th edition, because some P/N addition of O-ring for /PF option.

## **Jul. 2011/6th Edition Page layout changed by InDesign**

Page i, Reference manual number of FLXA21 added;  
Page 1-3, M4 ring terminals for FLXA21 added to MS-code;  
Page 1-5, M4 ring terminals added to external dimensions;  
CMPL 12B05J01-02E revised to 9th edition (Note for 500 ml KCl tank modified).

## **Mar. 2010/5th Edition**

Page 3-1 to 3-3, Section 3.1.1 has been changed to "Advance Preparation", and section order change as following, "3.1.2 Calibrating pH Sensor Using Buffer Solutions", "3.1.3 Pressurizing Reserve Tank", "3.1.4 Replenishment of KCl Solution", "3.1.5 Cleaning Glass Electrode and Liquid Junction". Some of Section 3.2.1 "Replacing Glass Electrode" modified; Page 3-4, Changing page of Section 3.2.3 "Replacing O-rings for Glass Electrode." ;  
CMPL 12B05J01-02E, The CMPL 12B05J01-02E has been revised to 8th edition.

## **Apr. 2008/4th Edition**

M3 ring terminals added for PH450G, CMPL12B05J01-02E revised to 7th edition.

## **Jul. 2006/3rd Edition**

All over revised.

## **Feb. 1996/2nd Edition**

Some error corrected.

## **Dec. 1995/1st Edition**

Newly published.

- 
- If you want to have more information about Yokogawa products, you can visit Yokogawa's home page at the following web site.  
Home page: <http://www.yokogawa.com/an>
-

*Thank you for selecting our Model PH8EFP KCl Filling type pH Sensor.*

*The User's Manual IM 12B7J1-01E 7th edition supplied with this product has been amended as follows, please make a note in your copy.*

Note

**CMPL 12B05J01-02E revised to 11th edition (The part No. and description of Item 3).**

# Customer Maintenance Parts List

## Model PH8EFP KCI Filling type pH Sensor

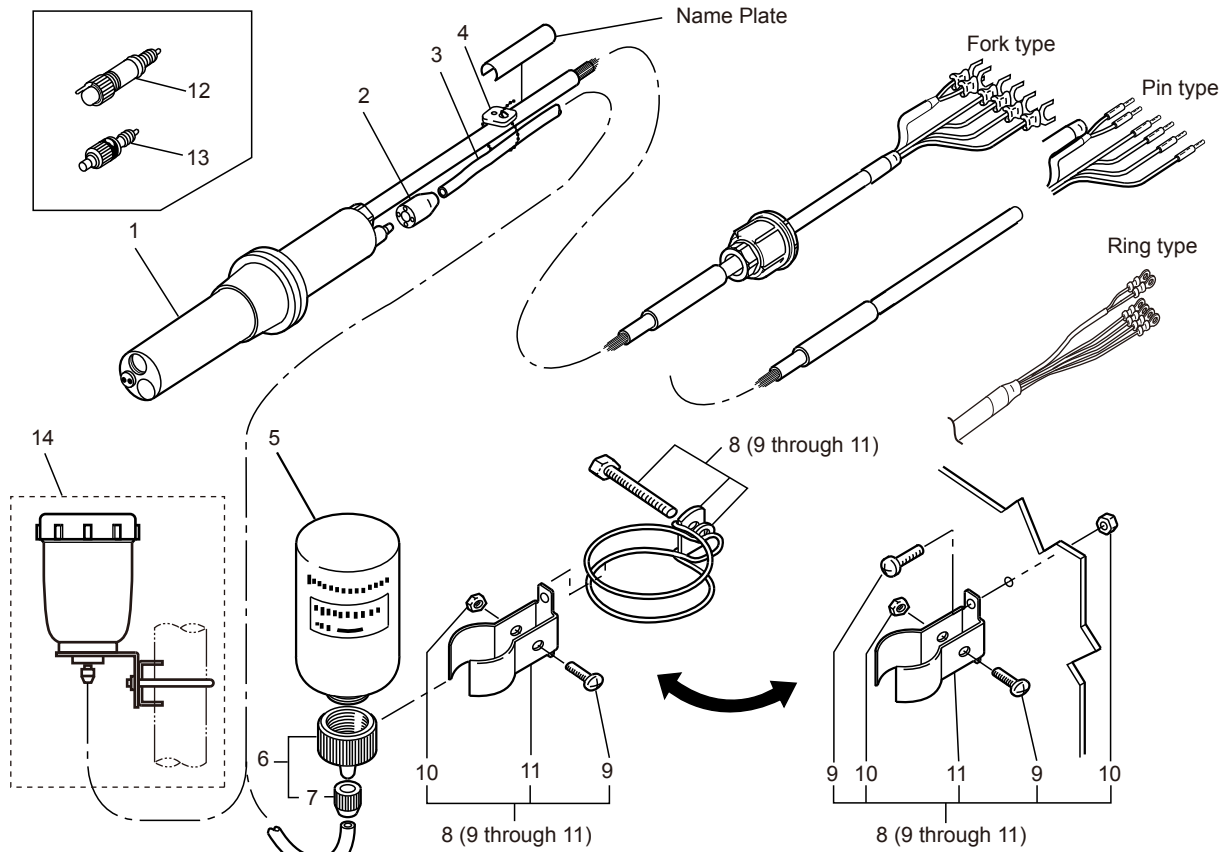

Item	Part No.	Qty	Description	Item	Part No.	Qty	Description
1	Below	1	Body Assembly see GS 12B07B02(E)	11	—	1	Bracket
2	K9142EJ	1	Cap	12	Below		Glass Electrode Assembly
3	Below	1	KCI Filling Tube		K9142TN	1	for general use
	K9142PF		Length 3 m		K9319NA	1	for PH8EFP/PF
	K9142PG		Length 5 m		K9319NC	1	for PH8EFP/HA and /PF
	K9142NH		Length 7 m		K9142TP	1	for Approved Under the Japanese Measurement Law ((K)
	K9142NJ		Length 10 m		K9319NB	1	for PH8EFP/PF Approved Law
	K9142NK		Length 15 m		K9142TU	1	for High Alkali of PH8EFP/HA
	K9142NL		Length 20 m		Below		O-Ring
	(L9901MB)		(Length by meter, max.100 m)		K9142QR	1	for general use, 6 mm ID. x 9 mm OD.
	K9142PJ		Length 3 m		K9142QS	1	for general use, 9 mm ID. x 12 mm OD.
	K9142PK		Length 5 m		K9319RB	1	for PH8EFP/PF, 6 mm ID. x 9 mm OD.
	K9142NM		Length 7 m		K9319RC	1	for PH8EFP/PF, 9 mm ID. x 12 mm OD.
	K9142NN		Length 10 m		13	Below	Junction Assembly
	K9142NP		Length 15 m		K9142TH	1	for general use
	K9142NQ		Length 20 m		K9319QA	1	for PH8EFP/PF
	(L9901CA)		(Length by meter, max.100 m)		K9142HW	1	for PH8EFP/TF
4	L9813UG	3 or 5	Clamp		K9319QB	1	for PH8EFP/TF and /PF
5	K9084KQ	1	Bottle for general use (250mL) (Suffix Code: -TT1)		K9142UH	1	for PH8EFP/CJ
					K9142UL	1	for PH8EFP/CJ and /PF
6	K9084KV	1	Connector Assembly (for general use)		Below		O-Ring
7	K9084CG	1	Nut		K9142QR	1	for general use, 6 mm ID. x 9 mm OD.
8	K9142VE	1	Holder Assembly		K9319RB	1	for PH8EFP/PF, 6 mm ID. x 9 mm OD.
9	—	3	B.H. Screw, M4x18	14	K9142VS	1	Tank assembly for use 500 mL (Suffix Code: -TT3)
10	—	3	Nut				

**Medium Pressure KCl Reserve Tank Assembly for Suffix Code: -TT2 ( K9142VG )**

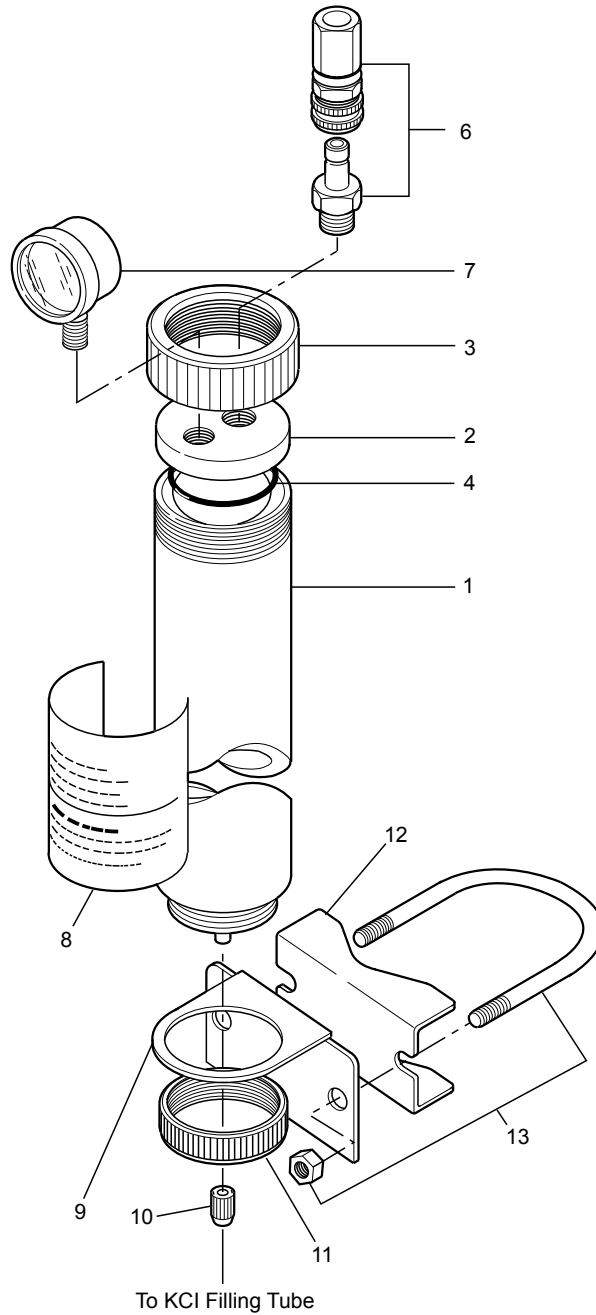

Item	Part No.	Qty	Description
1	K9142VL	1	Tank Assembly
2	K9142VJ	1	Block
3	K9142VK	1	Block
4	G9303AE	1	O-Ring
6	L9835DD	1	Joint
7	L9867BS	1	Pressure Gauge
8	K9142RU	1	Label
9	K9142VP	1	Bracket
10	K9142EJ	1	Cap
11	K9142VQ	1	Ring
12	L9826AL	1	Bracket
13	D0117XL-A	1	U-Bolt