**User's
Manual**

Model PH8EHP pH Sensor for High Purity Water

IM 12B7J2-01E

vigilantplant.[®]

Blank Page

◆ INTRODUCTION

This manual covers the PH8EHP pH Sensor for High Purity Water.

Other related items are described in the following manuals.

Model	Title	IM No.
PH8HH	pH Holder for High Purity Water	IM 12B07P01-01E
PH8AX	Accessories for pH Meter	IM 12B07W03-01E
PH400G	Four-wire Type pH Converter	IM 12B7C1-02E
PH450G	Four-wire Type pH Converter	IM 12B07C05-01E
PH202G, S	Two-wire Type pH Transmitter	IM 12B07D02-01E
PH202SJ	TIIS Intrinsic safe pH/ORP Transmitter	IM 12B07D02-11E
FLXA21	Two-wire Liquid Analyzer	IM 12A01A02-01E
WTB10-PH□	Terminal Box	IM 19D01B01-01E
PH8TBG	Terminal Box	IM 12B07W01-01E

◆ For the safe use of this equipment

■ Safety, Protection, and Modification of the Product

- In order to protect the system controlled by the product and the product itself and ensure safe operation, observe the safety precautions described in this user's manual. We assume no liability for safety if users fail to observe these instructions when operating the product.
- If this instrument is used in a manner not specified in this user's manual, the protection provided by this instrument may be impaired.
- Be sure to use the spare parts approved by Yokogawa Electric Corporation (hereafter simply referred to as YOKOGAWA) when replacing parts or consumables.
- Modification of the product is strictly prohibited.
- The following symbols are used in the product and user's manual to indicate that there are precautions for safety:

■ Notes on Handling User's Manuals

- Please hand over the user's manuals to your end users so that they can keep the user's manuals on hand for convenient reference.
- Please read the information thoroughly before using the product.
- The purpose of these user's manuals is not to warrant that the product is well suited to any particular purpose but rather to describe the functional details of the product.
- No part of the user's manuals may be transferred or reproduced without prior written consent from YOKOGAWA.
- YOKOGAWA reserves the right to make improvements in the user's manuals and product at any time, without notice or obligation.
- If you have any questions, or you find mistakes or omissions in the user's manuals, please contact our sales representative or your local distributor.

■ Warning and Disclaimer

The product is provided on an "as is" basis. YOKOGAWA shall have neither liability nor responsibility to any person or entity with respect to any direct or indirect loss or damage arising from using the product or any defect of the product that YOKOGAWA can not predict in advance.

■ Symbol Marks

Throughout this user's manual, you will find several different types of symbols are used to identify different sections of text. This section describes these icons.



WARNING

Indicates a potentially hazardous situation which, if not avoided, could result in death or serious injury.



CAUTION

Indicates a potentially hazardous situation which, if not avoided, may result in minor or moderate injury. It may also be used to alert against unsafe practices.



IMPORTANT

Indicates that operating the hardware or software in this manner may damage it or lead to system failure.



NOTE

Draws attention to information essential for understanding the operation and features.



Tip

This symbol gives information that complements the current topic.



SEE ALSO

This symbol identifies a source to be referred to.

◆ After-sales Warranty

- Do not modify the product.

- During the warranty period, for repair under warranty consult the local sales representative or service office. Yokogawa will replace or repair any damaged parts. Before consulting for repair under warranty, provide us with the model name and serial number and a description of the problem. Any diagrams or data explaining the problem would also be appreciated.
 - If we replace the product with a new one, we won't provide you with a repair report.
 - Yokogawa warrants the product for the period stated in the pre-purchase quotation. Yokogawa shall conduct defined warranty service based on its standard. When the customer site is located outside of the service area, a fee for dispatching the maintenance engineer will be charged to the customer.

- In the following cases, customer will be charged repair fee regardless of warranty period.
 - Failure of components which are out of scope of warranty stated in instruction manual.
 - Failure caused by usage of software, hardware or auxiliary equipment, which Yokogawa Electric did not supply.
 - Failure due to improper or insufficient maintenance by user.
 - Failure due to modification, misuse or outside-of-specifications operation which Yokogawa does not authorize.
 - Failure due to power supply (voltage, frequency) being outside specifications or abnormal.
 - Failure caused by any usage out of scope of recommended usage.
 - Any damage from fire, earthquake, storms and floods, lightning, disturbances, riots, warfare, radiation and other natural changes.

- Yokogawa does not warrant conformance with the specific application at the user site. Yokogawa will not bear direct/indirect responsibility for damage due to a specific application.

- Yokogawa Electric will not bear responsibility when the user configures the product into systems or resells the product.

- Maintenance service and supplying repair parts will be covered for five years after the production ends. For repair for this product, please contact the nearest sales office described in this instruction manual.

Model PH8EHP pH Sensor for High Purity Water

IM 12B7J2-01E 8th Edition

CONTENTS

- ◆ INTRODUCTIONi
- ◆ For the safe use of this equipmentii
- ◆ After-sales Warrantyiv
- 1. Specification 1-1
 - 1.1 Standard Specifications 1-1
 - 1.2 Model and Suffix codes 1-2
 - 1.3 External Dimensions 1-4
- 2. Installation 2-1
 - 2.1 Preparation for Installation 2-1
 - 2.1.1 Unpacking and Inspection 2-1
 - 2.1.2 Mounting Glass Electrode 2-2
 - 2.1.3 Mounting Liquid Junction 2-2
 - 2.1.4 Installing Holder 2-2
 - 2.1.5 Installing Associated Instruments 2-2
 - 2.2 pH Sensor Cable Wiring Procedure 2-3
 - 2.2.1 Connecting Sensor Cable 2-3
 - 2.2.2 Installing the sensor 2-4
- 3. Maintenance on operation 3-1
 - 3.1 Names of Component 3-1
 - 3.2 Operation and Periodic Maintenance 3-2
 - 3.2.1 Calibrating pH Sensor Using Buffer Solutions 3-2
 - 3.2.2 Replenishment of KCl Solution 3-2
 - 3.2.3 Cleaning Glass Electrode and Liquid Junction 3-2
 - 3.3 Replacing Consumable Parts 3-2
 - 3.3.1 Replacing Glass Electrode 3-2
 - 3.3.2 Replacing Liquid Junction 3-2
 - 3.3.3 Replacing O-rings for Glass Electrode 3-3
- Customer Maintenance Parts List CMPL 12B05J02-01E
- Revision Informationi

Blank Page

1. Specification

The Model PH8EHP pH Sensor is used to configure a pure water pH transmission system. When this sensor is used in a PH8HH pure water holder, it is possible to measure a low conductive solution at low flow rate accurately.

1.1 Standard Specifications

Measurement principle: Glass electrode method

Measuring range: 0 to 14 pH

Installation: Mounting in PH8HH holder

Temperature compensation sensor : Pt1000

Wetted part materials:

Body; Ryton (PPS resin), glass, titanium, ceramics, fluorocarbon rubber

Cable; Chlorinated polyethylene rubber (Cable sheath)

KCl solution supply tube: Heat-resistant soft PVC

Cable length : 3, 5, 7, 10, 15 or 20 m

Operating conditions :

Solution temperature : 0 to 50°C

Solution pressure : Under atmospheric pressure

Solution flow rate : 30 to 600 ml/min

Note : The maximum flow rate is restricted by the measured solution conductivity.

Solution conductivity: 0.1 μ S/cm or more (see following figure)

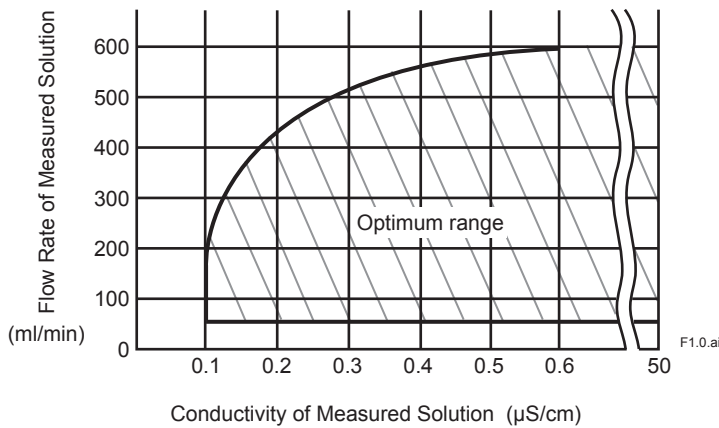

KCl solution consumption: Maximum 3 ml/day (10 kPa pressurized)

Weight: Sensor; Approx. 0.4 kg (Body), KCl Tank; Approx. 0.3 kg (General purpose), Approx. 0.8 kg (Big volume)

Characteristics :

Output Response: Response time (for 90% response): 10 seconds maximum (when the sensor, stabilized at 20°C, measures a solution at 20°C).

1.2 Model and Suffix codes

● pH Sensor

Model	Suffix Code	Option Code	Description
PH8EHP	pH sensor for high purity water
Cable Length	-03 -05 -07 -10 -15 -20	3m 5m 7m 10m 15m 20m
Solution Ground Tip	-TN	Titanium
KCl Reserve Tank (*1)	-TT1 -TT3 -TN1	For general purpose (250 ml solution inlet) Big volume tank (With 500 ml tank) For maintenance (for TT1)
—	-N	Always -N
Measuring System	-H -E -F -G	For PH200/PH400 (*2) For PH202/FLXA21 (*3) For FLXA21 (*5) For PH450G, PH202/TB (*4)
Style	*A	Style A

*1: Only a KCl supply tube is supplied with TN1. KCl solution is supplied with TT1 and TT3.

*2: Mark band is shown by mark and fork terminals are used.

*3: Mark band is shown by numeral and pin terminals are used.

*4: Mark band is shown by numeral and M3 ring terminals are used.
When terminal box is used, select WTB10-PH3.

*5: Mark band is shown by numeral and M4 ring terminals are used.
When terminal box is used, select WTB10-PH5.

● Accessories

Model	Suffix Code	Option Code	Description
PH8AX	Accessories for pH meter (*1)
Calibration Reagents	-L -P	Two bottles, each containing 250 ml solution (pH7 and pH4) 24 bags, each bag containing powder for 500 ml solution (pH7 X 12 bags and pH4 X 12 bags) and two 500 ml polyethylene bottles.
Style	*A	Style A
Option	/STD /KCLL /KCLP /TMP		Sensor stand (with mounting bracket for 50A 2-inch pipe) KCl solution (one 250 ml polyethylene bottle) KCl powder (three bags, 250 ml solution each) Thermometer (0 to 100 °C)

(*1): Including the following:
Two 200 ml polyethylene cups
One cleaning bottle

- Consumables

Part Name	Part Number	Remarks
Glass electrode	K9142TN	One
Junction	K9142TK	One
KCl solution (3.3 mol/l)	K9084LP	Six 250 ml polyethylene bottles
Buffer solution for calibration (pH 4)	K9084LL	Six 250 ml polyethylene bottles
Buffer solution for calibration (pH 7)	K9084LM	Six 250 ml polyethylene bottles
Buffer solution for calibration (pH 9)	K9084LN	Six 250 ml polyethylene bottles
Powder for buffer solution (pH 4)	K9020XA	12 bags, each for preparation of 500 ml
Powder for buffer solution (pH 7)	K9020XB	12 bags, each for preparation of 500 ml
Powder for buffer solution (pH 9)	K9020XC	12 bags, each for preparation of 500 ml
KCl powder (for PH8EHP)	K9020XU	8 bags, each for preparation of 250 ml

(Note) The pH value of the calibrating buffer solution may vary depending on storage conditions.
Prepare a new solution from powder for accurate instrument calibration

1.3 External Dimensions

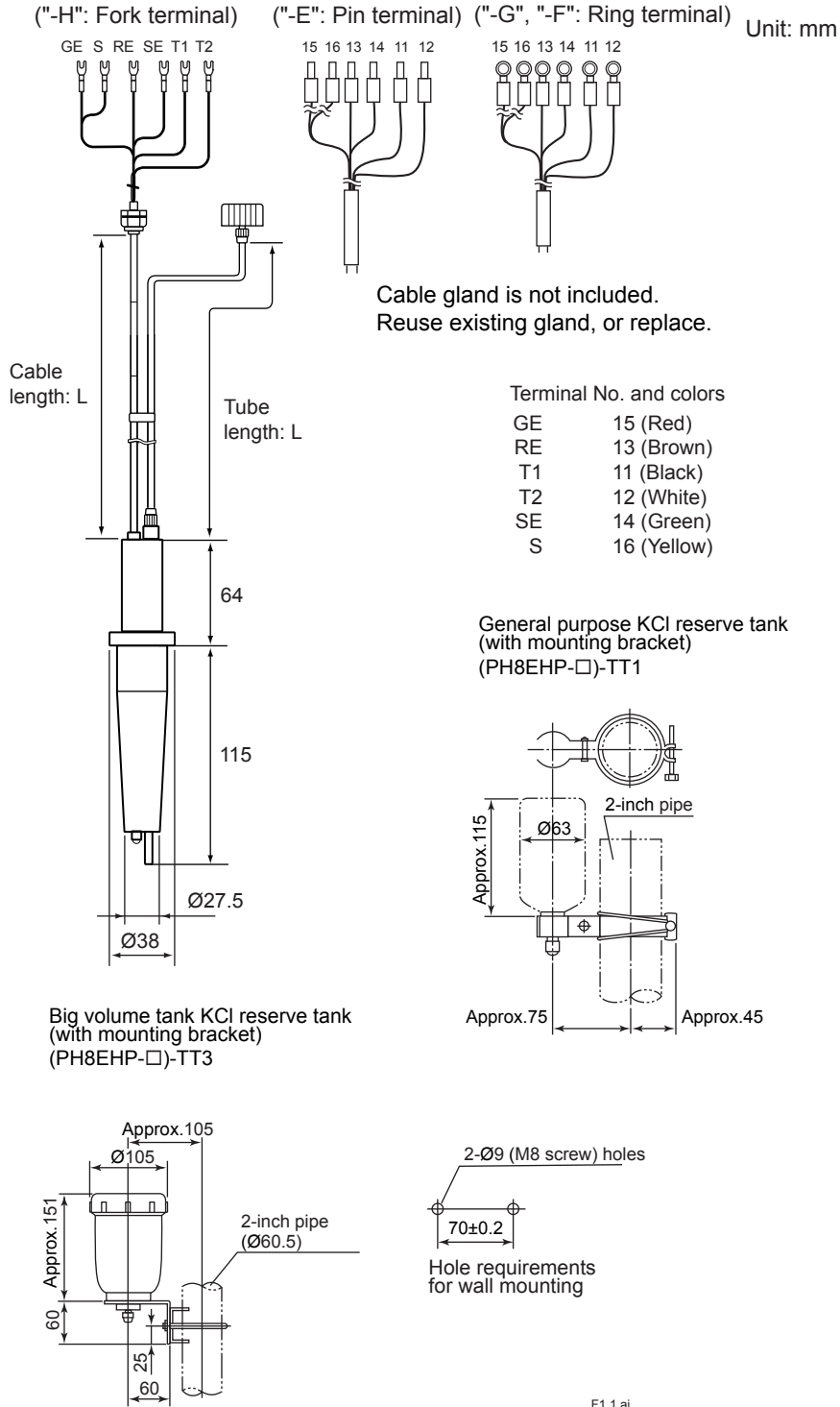

Figure 1.1 PH8EHP pH Sensor

2. Installation

2.1 Preparation for Installation

2.1.1 Unpacking and Inspection

The Model PH8EHP pH sensor is well packed so as to prevent damage during shipment.

After removing the sensor from its shipping container, visually check the sensor for damage.



NOTE

1. When delivered, the "glass electrode" and the "liquid junction" are packed separate from the sensor body.
2. So that caps of the "glass electrode" and the "liquid junction" do not dry out, do not take unpack these at this time.

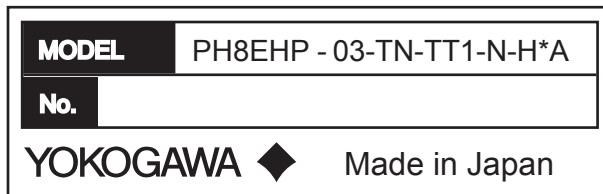

F2.1.ai

Figure 2.1 An Example of Model Number Entering to Nameplate

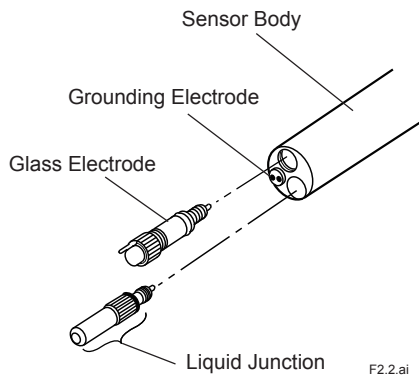

F2.2.ai

Figure 2.2 Names of PH8EHP pH Sensor Components

2.1.2 Mounting Glass Electrode

Mount the glass electrode on the sensor body as per the following procedure:

- (1) Peel off the seal from the electrode mounting hole on the sensor body.
- (2) Remove the cap for the glass membrane. Wipe off any solution remaining on the O-ring with a tissue or other material.
- (3) Remove the cap for the gold-plated pin.
- (4) Confirm that there is no damage on the O-ring that might affect its sealing performance.
- (5) Mount the glass electrode on the sensor body. Insert the electrode in the mounting hole and screw it clockwise until the O-ring fits tightly in the hole.



NOTE

- As shown in Figure (a), the cap for the glass membrane contains the solution to keep wet (pH4 buffer solution). Do not splash the solution when removing the cap. Remove the cap carefully because the rod beside the glass membrane is very fragile.
- Before mounting the glass electrode on the sensor body, make sure that the O-ring and the gold-plated pin are not wet. Wipe off any remaining solution.
- Make sure that there are no droplets in the mounting hole. Wipe off any droplets, or they may cause insulation failure.
- Use the electrode within one year after purchase. The solution to keep wet gradually evaporates over time. A glass electrode whose glass membrane has dried out does not provide stable readings until it gets used to the solution. As shown in Figure (b), place in advance the glass electrode either in the pH4 or pH7 buffer solution for more than a day before using.

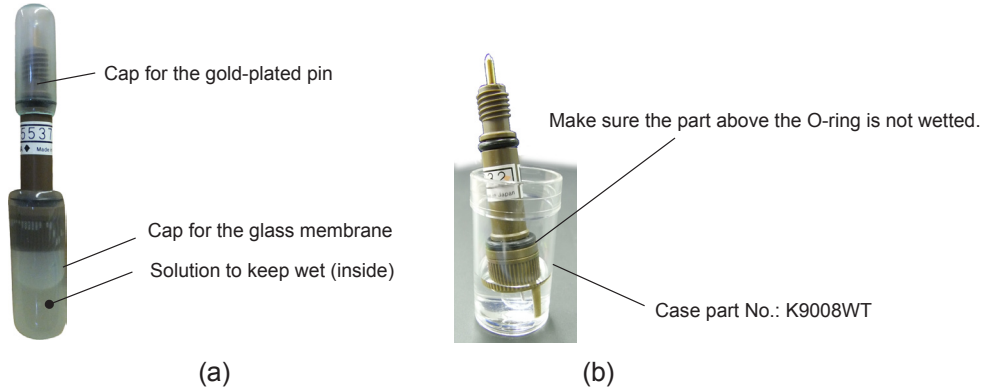

2.1.3 Mounting Liquid Junction

The liquid junction is mounted in the sensor body when the KCl solution is poured into the sensor body. Refer to Section 2.2.

2.1.4 Installing Holder

Usually, the pH sensor is suspended in a guide pipe or installed in a flow-through or submersible holder. First install the holder.

2.1.5 Installing Associated Instruments

Make sure that the associated instrument (a pH transmitter/converter or a junction terminal box) to which the pH sensor cable is connected has already been installed.

2.2 pH Sensor Cable Wiring Procedure

2.2.1 Connecting Sensor Cable

- **Connecting Sensor Cable to Terminal Box**

- (1) Open the cable inlet hole in terminal box using the supplied punch tool. The location of the cable inlet hole is shown by the circle-shaped groove under the case. The end of the supplied punch tool is put in the center of this circle and it is tapped with appropriate force. You can punch out the hole along the groove.

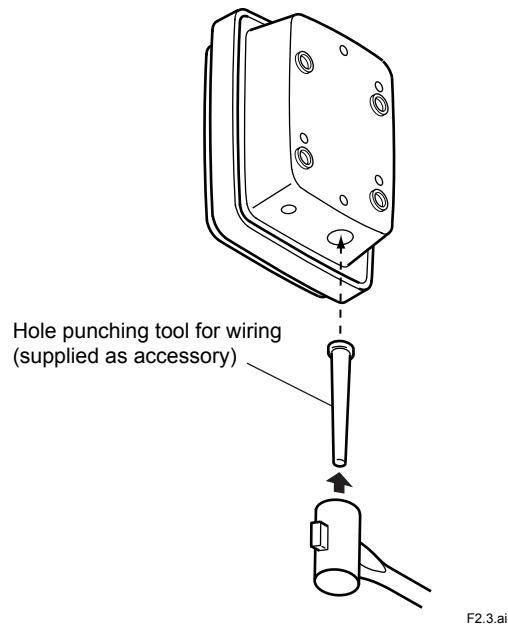

Figure 2.3 How to punch out the wiring hole

- (2) Loosen two screws which are at front of terminal box and detach the cover.
- (3) After detaching the nut from the cable gland of sensor cable, pull the cable into the terminal box from sensor cable inlet hole.

Connect the sensor cable to the terminals.

After passing the cable through the nut, check the symbol on each core wire, then connect each core wire to the corresponding terminal.

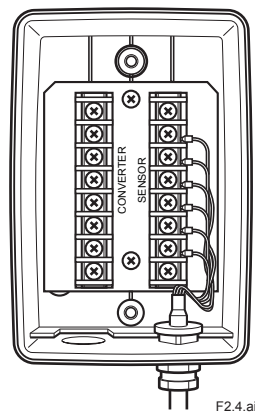

Figure 2.4 Connecting Sensor Cable (In case of the PH8TBG)

- (4) Mount the cable gland in the cable inlet hole.

Put the nut in place, and screw it onto the main body sufficiently. At this time, loosen the cap so that the cable is not twisted. After fixing the main body, tighten the cap to keep moisture out of the equipment. However if the cap is screwed up too tight, the cable will be damaged.

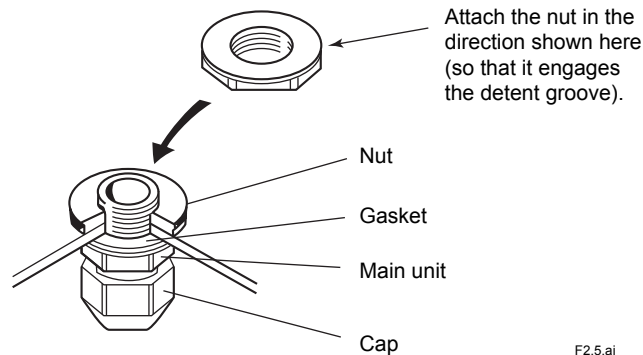

Figure 2.5 Cable Gland

- (5) After completing the cable connections, replace the box cover securely, thus preventing moisture from getting into the case.

● Connecting Sensor Cable to pH Transmitter/Converter

To connect the sensor cable to the two-wire pH transmitter, proceed as follows:

- (1) Loosen the four screws that tighten the transmitter cover. Then remove the transmitter cover.
- (2) Connect the sensor cables to the relevant terminals of the transmitter/converter:

First, remove the nut from the cable gland. Insert the cable into the right opening for the wiring. Then pass the cable through the nut, Connect the individual cable conductors to the relevant terminals correctly by referring to the markings on the individual conductors.

- (3) Install the cable gland in the wiring hole as follows:

Pass the tip of the cable gland into the opening and completely tighten the gland with the nut inside the case.

After tightening the gland, secure the cap properly to prevent moisture from getting into the case.

Caution: Do not overly tighten the cap. Otherwise, the cable may be damaged.

- (4) After completing the cable connections, replace the transmitter/converter cover securely, thus preventing moisture from getting into the case.

For details, refer to the relevant user's manuals for pH transmitter/converter.

2.2.2 Installing the sensor

- (1) Mount the liquid junction in the sensor body. Peel off the seal attached to the liquid junction mounting hole in the sensor body. Screw the liquid junction gently two or three turns into the hole.
- (2) The PH8EHP pH sensor comes with a KCl solution reserve tank and its mounting hardware when specified. Attach the mounting hardware to the pipe (nominal diameter 50 mm).

When suffix code "-TT1" is specified, connect the KCl solution refilling tube of the sensor to the general purpose reserve tank holding a 250 ml KCl solution. With the tube connected to the sensor, remove the cap from the tank and screw the connector of the tube in securely.

When suffix code "-TT3" is specified, connect the KCl solution refilling tube of the sensor to the Big-volume reserve tank holding a 500 ml KCl solution.

- (3) Supply a KCl solution to the sensor.

For the 250-ml KCl reserve tank, mount the reserve tank on the mounting hardware with the tube connection part facing down. Using a pin supplied with the tank, make several holes in the upper part of the sides of the tank (see Figure 2.6).

Stand the sensor upside down at a lower position than the reserve tank as shown in Figure 2.6 so that KCl solution flows from the tank into the sensor. When the KCl solution fills the sensor and overflows from the liquid junction mounting hole, securely screw the liquid junction into the mounting hole.



CAUTION

How to screw liquid junction

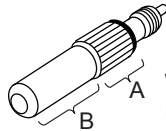

When you screw the liquid junction into the mounting hole, grip and rotate the "A" (brown body). If you grip and rotate the "B" (black body), the liquid junction may be broken.

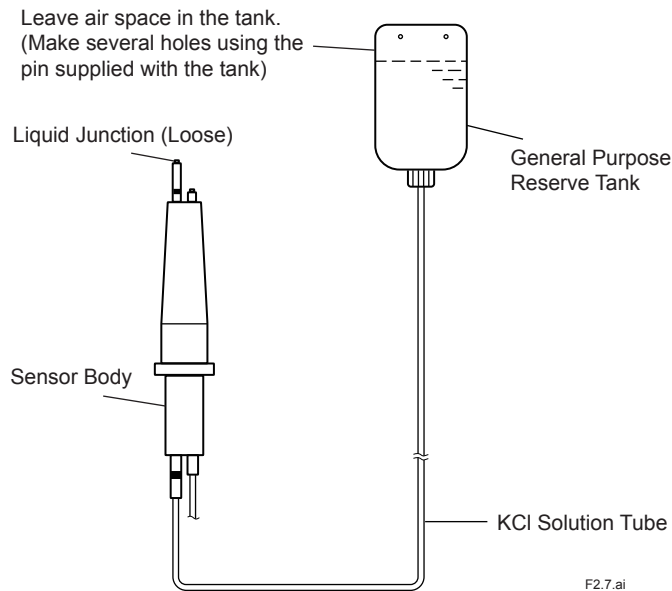

Figure 2.6 Supplying KCl Solution to Sensor Body

For the 500-ml KCl reserve tank, supply a KCl solution to the reserve tank and close the cover. Be sure to hold the reserve tank by hand when opening or closing the cover. Also, when further tightening the fixing nut at the bottom of the reserve tank, be careful not to tighten it too tight. Excessive tightening may cause cracks in the reserve tank.

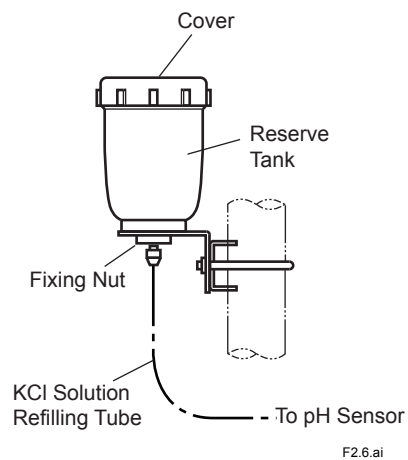

Figure 2.7 500-ml Reserve Tank



CAUTION

After supplying the KCl solution, make sure that no leakage of KCl solutions occurs. If so, grounding connections will be made at two points. This may cause unstable readings or measurement errors.

- (4) Install the pH sensor to the holder. Insert the pH sensor in the liquid chamber until the liquid junction in the sensor reaches the bypass in the liquid chamber and secure the sensor with metal clamp. If the solution does not pass the bypass, remove the sensor from the solution chamber and submerge it in a container filled with water.

This prevents the glass electrode from being dry out or KCl solution — flowed out of the liquid junction — from being crystallized.

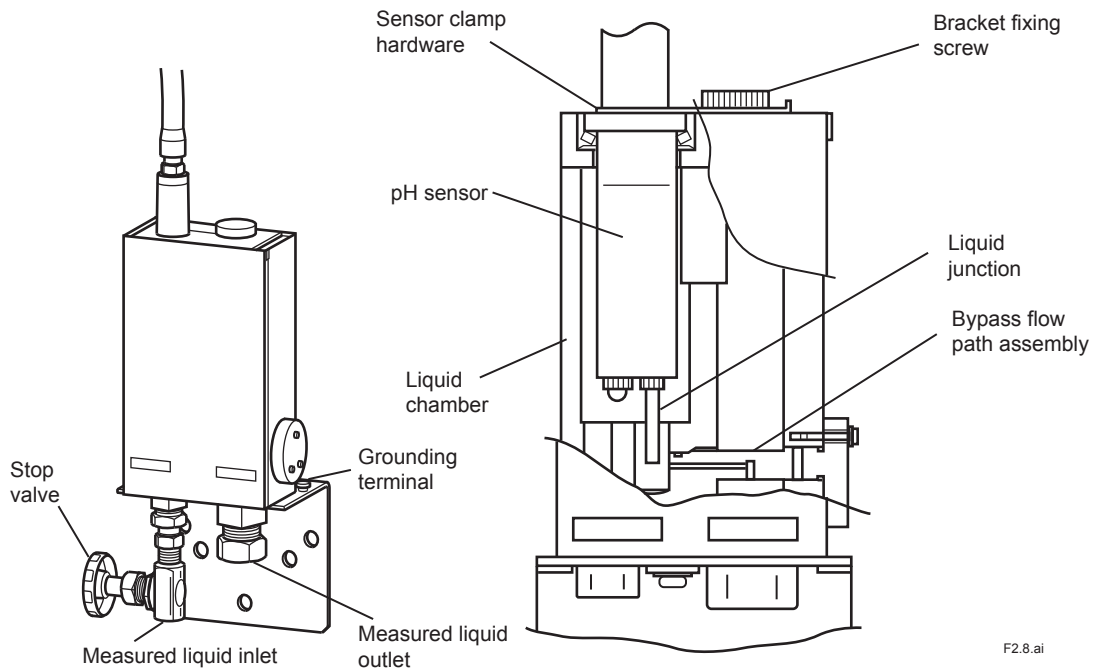

F2.8.ai

Figure 2.8 pH Sensor Installation

3. Maintenance on operation

3.1 Names of Component

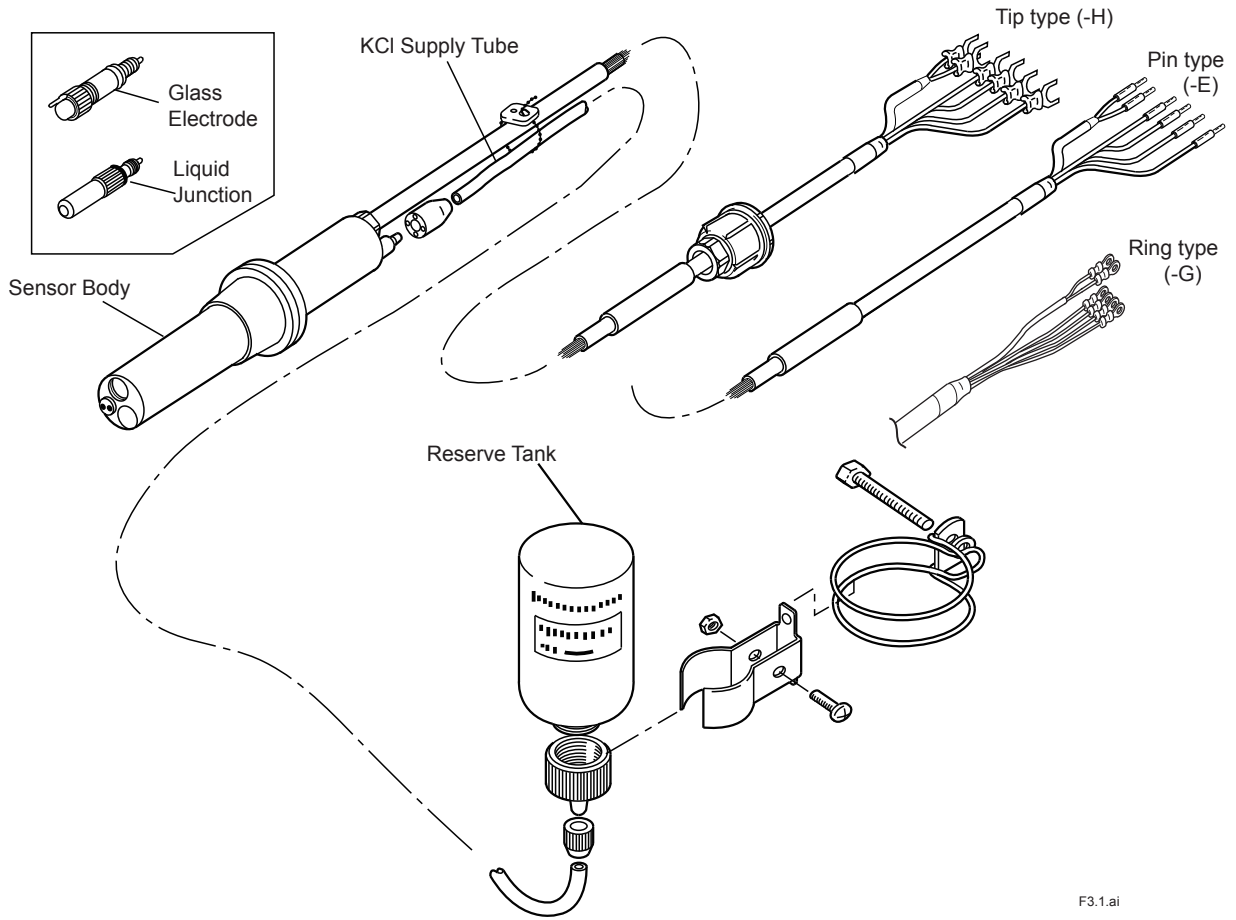

Figure 3.1 Names of Component of PH8EHP pH Sensor

3.2 Operation and Periodic Maintenance

3.2.1 Calibrating pH Sensor Using Buffer Solutions

Calibrate pH sensor with buffer solutions before starting normal operation because the emf of glass electrodes differs somewhat from each other.

The emf of a glass electrode gradually changes due to electrode staining or deterioration.

Therefore, buffer solution calibration must be carried out periodically within a given period of time to keep the measurement errors within the limits specified.

For more detailed information on the calibration procedures, see relevant pH transmitter/converter IMs.

3.2.2 Replenishment of KCl Solution

When the KCl solution in the tank seems to be nearly exhausted while using a pH sensor with general type reserve tank, replace the reserve tank with new one (provided separately as spare part).

Instead of tank replacement, when a KCl solution prepared using KCl powder is used for replenishment, use 3.3 mol/l solution by dissolving 246 g of KCl powder in pure water to make exactly one liter of solution. When pouring the solution into the tank, be careful that KCl solution does not overflow from the vent holes of the tank.

3.2.3 Cleaning Glass Electrode and Liquid Junction

Staining of a glass electrode or liquid junction can cause measurement errors. Therefore, if its measured solutions tend to stain the electrode, the glass electrode and liquid junction must be cleaned periodically — the period depending on the degree of staining.

Submerge the glass electrode in a diluted hydrochloric acid solution (1 to 2 %) for several minutes.

3.3 Replacing Consumable Parts

3.3.1 Replacing Glass Electrode

If buffer solution calibration becomes impossible due to deterioration of the glass electrode, replace it with a new one. After the glass electrode is replaced, always carry out a buffer solution calibration.

3.3.2 Replacing Liquid Junction

Even after washing the liquid junction, if normal measurement cannot be made, replace the liquid junction.

When replacing the liquid junction, fill the sensor with KCl solution to just before the solution overflows through the liquid junction mounting hole. Use a 3.3 mol/l KCl solution (a higher concentration of KCl or KCl powder) for this application.

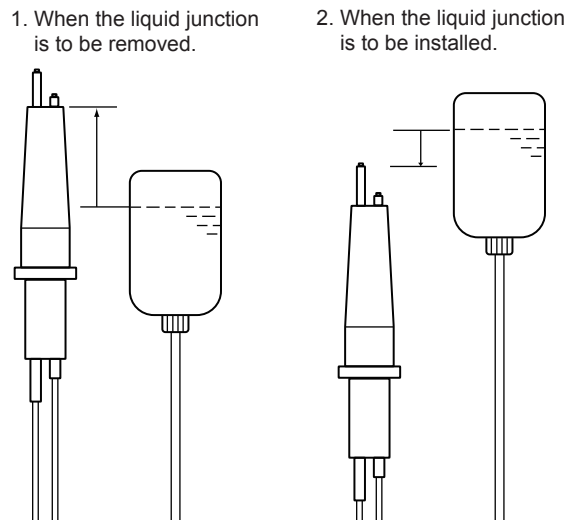

Figure 3.2 Replacing Liquid Junction

3.3.3 Replacing O-rings for Glass Electrode

As the inside of the glass electrode mounting hole must have high insulation resistance, fluorocarbon rubber O-rings - with superior chemical and heat resistance - are used for sealing. Except for special uses. If any damage - which might cause problems - is detected in the O-ring, as a rule, replace it along with the glass electrode.

Although the O-ring can be replaced individually if the O-ring deteriorates much faster than the glass electrode, it is recommended that the whole glass electrode be replaced to avoid possible deterioration of the O-ring inside the glass electrode. For individual replacement of the O-ring, use the one recommended by Yokogawa.

When installing the O-ring, wind a slip of paper or tape around the thread part on the glass electrode so as not to scratch the O-ring. Otherwise, such scratches may damage its sealing properties.

For ordering, refer to the Customer Maintenance Parts List (CMPL) at the end of the book to check the appropriate part number of the O-ring.

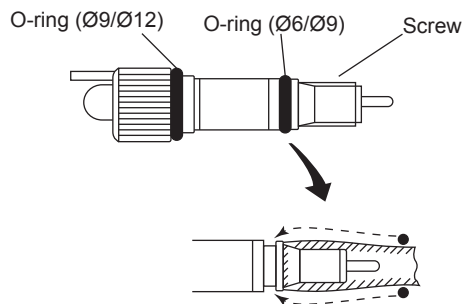

Before installing, wind a slip of paper or tape around the thread part to prevent scratches.

Figure 3.3 Installing the O-ring

Blank Page

Customer Maintenance Parts List

Model PH8EHP pH Sensor for Purity Water

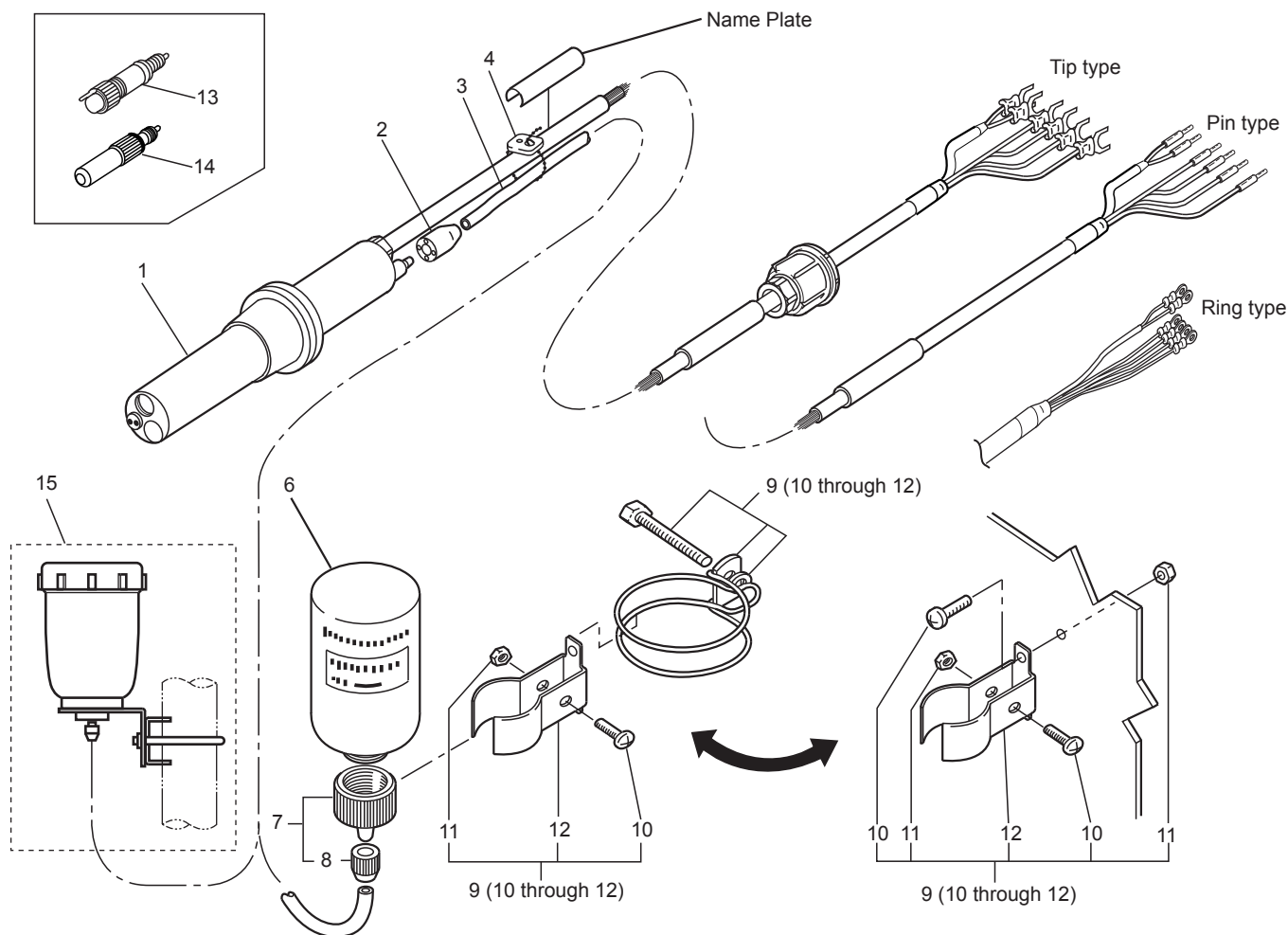

Item	Part No.	Qty	Description	Item	Part No.	Qty	Description
1	Below	1	Body Assembly see GS 12B07B02(E)	9	K9142VE	1	Holder Assembly
2	K9142EJ	1	Cap	10	—	3	B.H. Screw, M4 X 18
3	Below	1	KCl Filling Tube	11	—	3	Nut
	K9142PF		Length 3 m	12	—	1	Bracket
	K9142PG		Length 5 m	13	Below	1	Glass Electrode Assembly for general use
	K9142NH		Length 7 m		K9142QR	1	O-Ring, 6 mm ID. X 9 mm OD.
	K9142NJ		Length 10 m		K9142QS	1	O-Ring, 9 mm ID. X 12 mm OD.
	K9142NK		Length 15 m	14	Below	1	Junction Assembly for pure water use
	K9142NL		Length 20 m		K9142TK	1	
	L9901MB		Length m step (max.100)		K9142VR	1	O-Ring, 6 mm ID. X 9 mm OD.
4	L9813UG	3 or 5	Clamp	15	K9142VS	1	Tank assembly for use 500 ml (Suffix Code: -TT3)
6	K9084KQ	1	Bottle for general use (250ml) (Suffix Code: -TT1)				
7	K9084KV	1	Connector Assembly (for general use)				
8	K9084CG	1	Nut				

Revision Information

- Title : Model PH8EHP pH Sensor for High Purity Water
- Manual No. : IM 12B7J2-01E

Jun. 2013/8th Edition

P 1-1 Some revision of Sec. 1.1 Standard Specifications; P 2-1 to 2-2 Some revision of Sec. 2.1.1 and 2.1.2 (addition of the cap to keep the glass electrode wet); P 2-5 to 2-6 Addition of caution to screw the liquid junction; P 3-2 to 3-3 Deletion of Sec. 3.2.1 (how to keep the glass electrode wet moved to Sec. 2.1.2) and following section no. and page layout changed.

Jul. 2011/7th Edition Page layout changed by InDesign

P i, Reference manual number of FLXA21 added.
P 1-2, M4 ring terminals for FLXA21 added to MS-code.
P 1-4, M4 ring terminals added to external dimensions.
CMPL 12B05J02-01E revised to 6th edition (Note for 500 ml KCl tank modified).

Mar. 2010/6th Edition

P3-1 to 3-2, Section 3.2.1 has been changed to "Advance Preparation", and section order change as following. "3.2.2 Calibrating pH Sensor Using Buffer Solutions", "3.2.3 Replenishment of KCl Solution", "3.2.4 Cleaning Glass Electrode and Liquid Junction". Some of Section 3.3.1 "Replacing Glass Electrode" modified;
P3-4, Changing page of Section 3.3.2 "Replacing Liquid Junction."

Apr. 2008/5th Edition

M3 ring terminals added for PH450G, CMPL12B05J02-01E revised to 5th edition.

Oct. 2006/4th Edition

Caution for KCl solution leakage of reserve tank added to 2.2.4 Installing the sensor.

Jul. 2006/3rd Edition

All over revised.

Feb. 1993/2nd Edition

Some error corrected.

Dec. 1983/1st Edition

Newly published.

-
- If you want to have more information about Yokogawa products, you can visit Yokogawa's home page at the following web site.
Home page: <http://www.yokogawa.com/an>
-

Thank you for selecting our Model PH8EHP pH Sensor for High Purity Water.

The User's Manual IM 12B7J2-01E 8th edition supplied with this product has been amended as follows, please make a note in your copy.

Note

CMPL 12B05J02-01E revised to 7th edition (The part No. and description of Item 3).

Customer Maintenance Parts List

Model PH8EHP pH Sensor for Purity Water

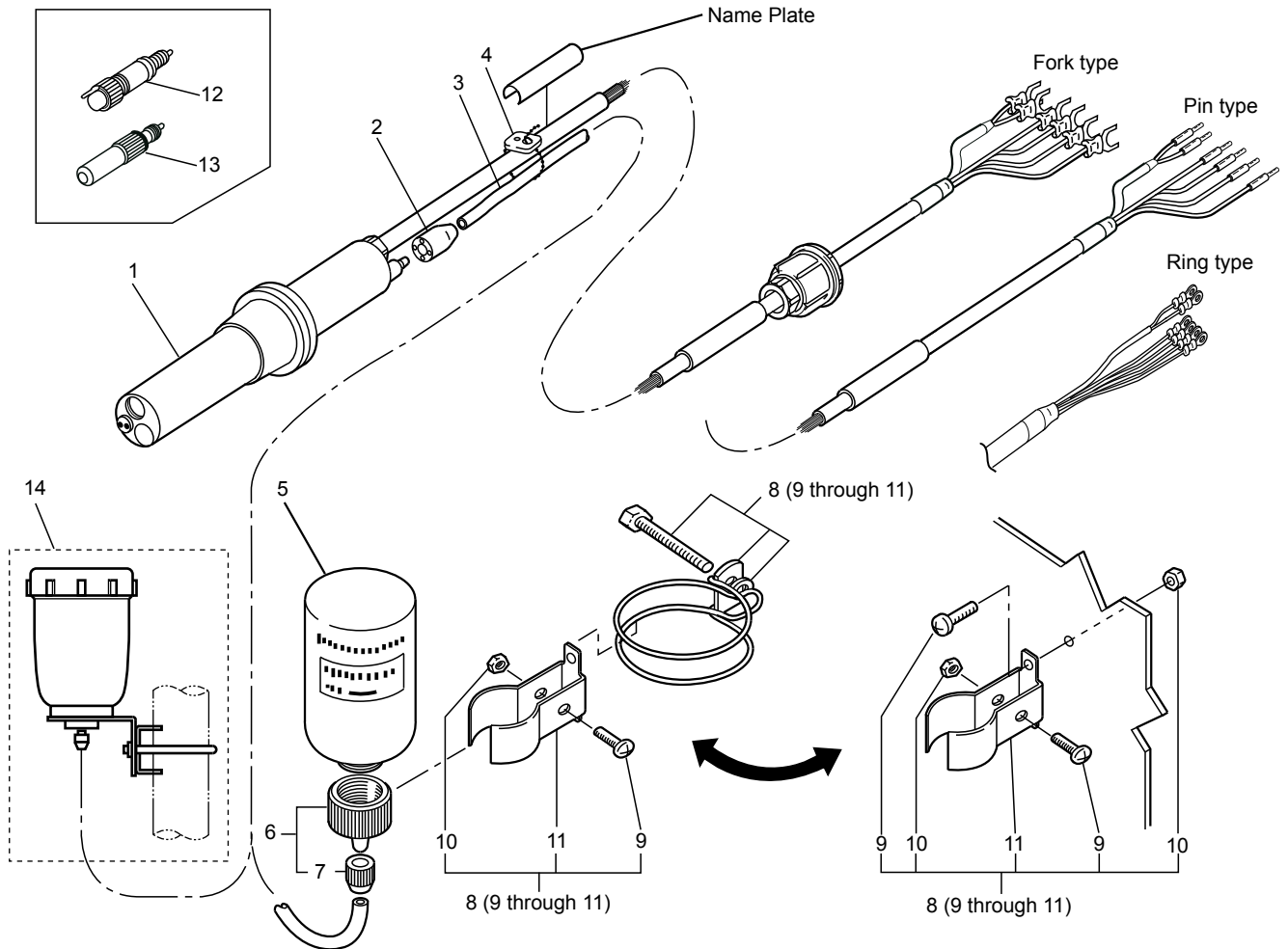

Item	Part No.	Qty	Description	Item	Part No.	Qty	Description
1	Below	1	Body Assembly see GS 12B07B02(E)	8	K9142VE	1	Holder Assembly
2	K9142EJ	1	Cap	9	—	3	B.H. Screw, M4 X 18
3	Below	1	KCl Filling Tube Length 3 m K9142PF Length 5 m K9142PG Length 7 m K9142NH Length 10 m K9142NJ Length 15 m K9142NK Length 20 m K9142NL (L9901MB)	10	—	3	Nut
4	L9813UG	3 or 5	Clamp	11	—	1	Bracket
5	K9084KQ	1	Bottle for general use (250mL) (Suffix Code: -TT1)	12	Below	1	Glass Electrode Assembly for general use
6	K9084KV	1	Connector Assembly (for general use)	K9142TN	K9142TN	1	O-Ring, 6 mm ID. X 9 mm OD.
7	K9084CG	1	Nut	K9142QR	K9142QR	1	O-Ring, 9 mm ID. X 12 mm OD.
				13	Below	1	Junction Assembly for pure water use
				K9142TK	K9142TK	1	O-Ring, 6 mm ID. X 9 mm OD.
				14	K9142VS	1	Tank assembly for use 500 mL (Suffix Code: -TT3)