

Unit: mm (approx. inch)

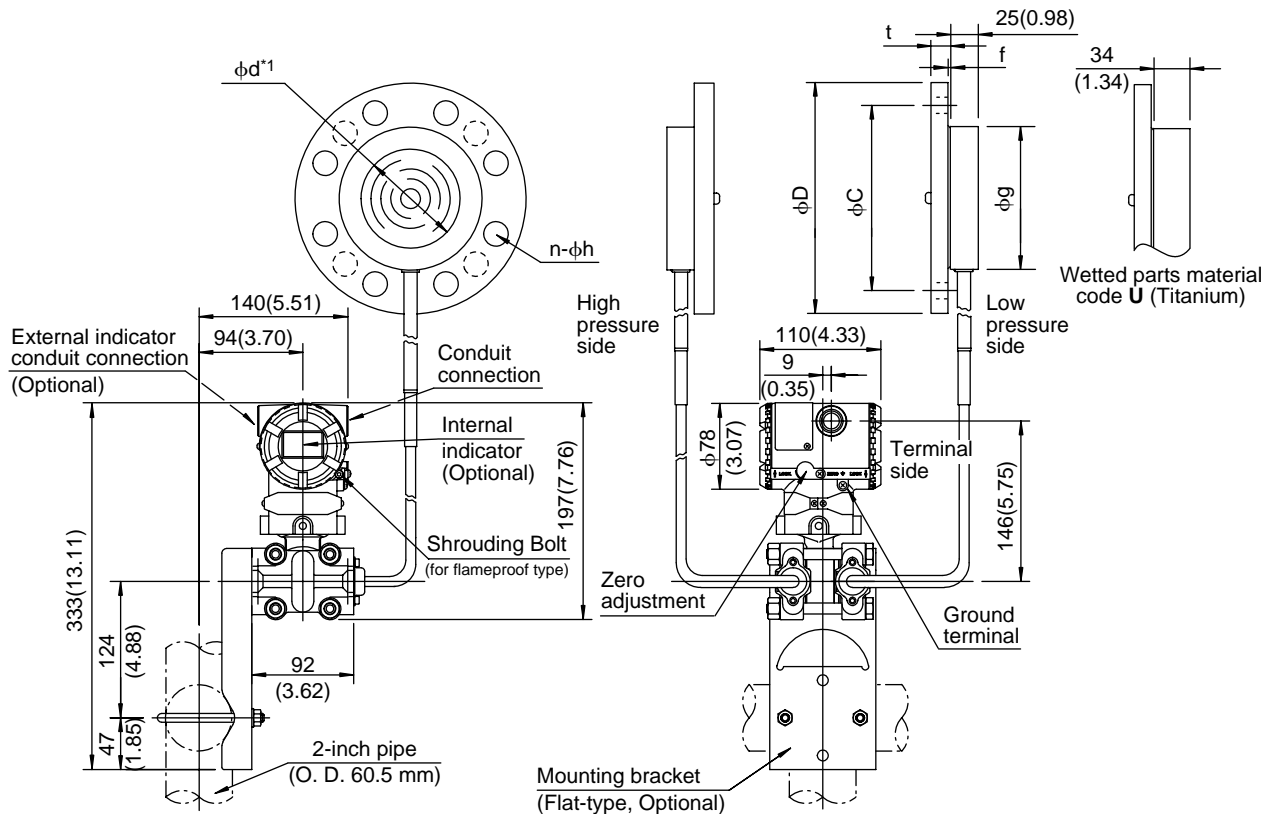

*1: Indicates inside diameter of gasket contact surface.

Process flange size: 3-inch (80mm)

Flange Rating	ϕD	ϕC	ϕg	ϕd	t	f*2	n	ϕh
JIS 10K	185(7.28)	150(5.91)	130(5.12)	90(3.54)	18(0.71)	0	8	19(0.75)
JIS 20K	200(7.87)	160(6.30)	130(5.12)	90(3.54)	22(0.87)	0	8	23(0.91)
JIS 40K	210(8.27)	170(6.69)	130(5.12)	90(3.54)	32(1.26)	0	8	23(0.91)
ANSI Class 150	190.5(7.50)	152.4(6)	130(5.12)	90(3.54)	23.9(0.94)	1.6(0.06)	4	19.1(0.75)
ANSI Class 300	209.6(8.25)	168.1(6.62)	130(5.12)	90(3.54)	28.5(1.12)	1.6(0.06)	8	22.4(0.88)
ANSI Class 600	209.6(8.25)	168.1(6.62)	130(5.12)	90(3.54)	38.2(1.50)	6.4(0.25)	8	22.4(0.88)
JPI Class 150	190(7.48)	152.4(6)	130(5.12)	90(3.54)	24(0.94)	1.6(0.06)	4	19(0.75)
JPI Class 300	210(8.27)	168.1(6.62)	130(5.12)	90(3.54)	28.5(1.12)	1.6(0.06)	8	22(0.87)
JPI Class 600	210(8.27)	168.1(6.62)	130(5.12)	90(3.54)	38.4(1.51)	6.4(0.25)	8	22(0.87)
DIN PN 10/16	200(7.78)	160(6.30)	130(5.12)	90(3.54)	20(0.79)	0	8	18(0.71)
DIN PN 25/40	200(7.78)	160(6.30)	130(5.12)	90(3.54)	24(0.94)	0	8	18(0.71)
DIN PN 64	215(8.46)	170(6.69)	130(5.12)	90(3.54)	28(1.10)	0	8	22(0.87)

Terminal Configuration

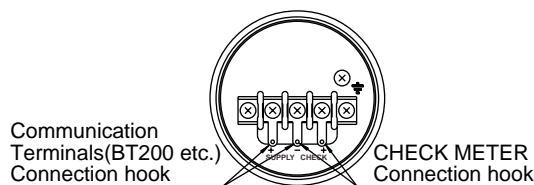

Terminal Wiring

SUPPLY \pm	Power supply and output terminal
CHECK \pm	External indicator(ammeter) terminal
⏏	Ground terminal

Process flange size: 2-inch (50mm)

Flange Rating	ϕD	ϕC	ϕg	ϕd	t	f*2	n	ϕh
JIS 10K	155(6.10)	120(4.72)	100(3.94)	61(2.40)	16(0.63)	0	4	19(0.75)
JIS 20K	155(6.10)	120(4.72)	100(3.94)	61(2.40)	18(0.71)	0	8	19(0.75)
JIS 40K	165(6.50)	130(5.12)	100(3.94)	61(2.40)	26(1.02)	0	8	19(0.75)
ANSI Class 150	152.4(6.00)	120.7(4.75)	100(3.94)	61(2.40)	19.1(0.75)	1.6(0.06)	4	19.1(0.75)
ANSI Class 300	165.1(6.50)	127.0(5.00)	100(3.94)	61(2.40)	22.4(0.88)	1.6(0.06)	8	19.1(0.75)
ANSI Class 600	165.1(6.50)	127.0(5.00)	100(3.94)	61(2.40)	31.8(1.25)	6.4(0.25)	8	19.1(0.75)
JPI Class 150	152(6.10)	120.6(4.75)	100(3.94)	61(2.40)	19.5(0.77)	1.6(0.06)	4	19(0.75)
JPI Class 300	165(6.50)	127.0(5.00)	100(3.94)	61(2.40)	22.5(0.89)	1.6(0.06)	8	19(0.75)
JPI Class 600	165(6.50)	127.0(5.00)	100(3.94)	61(2.40)	31.9(1.26)	6.4(0.25)	8	19(0.75)
DIN PN 10/16	165(6.50)	125(4.92)	100(3.94)	61(2.40)	18(0.71)	0	4	18(0.71)
DIN PN 25/40	165(6.50)	125(4.92)	100(3.94)	61(2.40)	20(0.78)	0	4	18(0.71)
DIN PN 64	180(7.09)	135(5.31)	100(3.94)	61(2.40)	26(1.02)	0	4	22(0.87)

*2: In case where process flange material is JIS S25C, value of f is 0.